

Advanced Multi-Circuit Meter 7000 Series User's Guide

Cat. Nos. 71C03, 71C12, 71C24, 71C48 71D12, 71D48, 70D12, 70D48,
71D24, 70D24, 71D03, 70D03



Cat. 71D12



Cat. 71D24 and 71D48



Cat. 70D12



Cat. 70D48



Cat. 70D03



Cat. 71D03



Cat. 70D24

TABLE OF CONTENTS

1	Warnings and Cautions	4
2	Introduction	6
3	Planning for Field Installation	9
4	Meter Configuration	11
5	Meter Installation.....	23
6	Communication & Verification	34
7	RTU Programming & Scripting.....	48
8	Appendix A: LCD Menu Navigation	62
9	Appendix B: Technical Specifications.....	65
10	Standard Statements and Warranty	67

1 WARNINGS AND CAUTIONS

WARNINGS:

- **HAZARD OF ELECTROCUTION, SHOCK, EXPLOSION, OR ARC FLASH. CAREFULLY READ AND FOLLOW INSTRUCTIONS.**
- **TO AVOID FIRE, SHOCK OR DEATH,** turn OFF all power supplying equipment before working on or inside the equipment. Use a properly rated voltage sensing device to confirm power is OFF.
- Follow safe electrical work practices. See NFPA 70E in the USA, or applicable local codes.
- This equipment **MUST** be installed and serviced by an electrician or other qualified personnel with the requisite knowledge, training, and experience related to the installation and operation of this equipment.
- Product may use multiple voltage/power sources. Be sure all sources of power have been disconnected before servicing.
- Do not depend on this product for voltage indication.
- Only install this product on insulated conductors.
- If the meter appears damaged or defective, first disconnect all power to the meter. Then call or e-mail technical support for assistance.

DO NOT EXCEED 346V Line to Neutral (L-N) or 600V Line to Line (L-L). This meter is equipped to monitor loads up to 346V L-N. Exceeding this voltage will cause damage to the meter and danger to the user. Always use a Potential Transformer (PT) for voltages in excess of 346V L-N or 600 volts L-L. VerifEye® branded meters are 600 Volt Over Voltage Category III devices.

For use in a Pollution Degree 2 or better environment only. A Pollution Degree 2 environment must control conductive pollution and the possibility of condensation or high-humidity. Consider the enclosure, the correct use of ventilation, thermal properties of the equipment, and the relationship with the environment.

Installation category: CAT II or CAT III.

Provide a disconnect device to disconnect the meter from the supply source. Place this device in close proximity to the equipment, within easy reach of the operator, and mark it as the disconnecting device. The disconnecting device must meet the relevant requirements of IEC 60947-1 and IEC 60947-3, and be suitable for the application. In the US and Canada, disconnecting fuse holders can be used. Provide over-current protection and disconnecting device for supply conductors with approved current-limiting devices suitable for protecting the wiring. If the equipment is used in a manner not specified by the manufacturer, the protection provided by the device may be impaired.

1 WARNINGS AND CAUTIONS

CAUTIONS:

- This product is not intended for life or safety applications.
- Do not install this product in hazardous or classified locations.
- The installer is responsible for compliance with all applicable codes.
- Mount this product inside a suitable fire and electrical enclosure.
- If the collector is connected directly to a source of voltage, the pulse isolator burns out immediately and becomes non-responsive.
- Do not use any cleaning agents, including water, on the device.
- No accessories are approved for use with the meter other than those specified in the Leviton Manufacturing product literature and price sheets.
- A circuit breaker used as a disconnect must meet the requirements of IEC 60947-1 and IEC 60947-3 (Clause 6.11.4.2).
- Current transformers may not be installed in equipment where they exceed 75 percent of the wiring space of any cross-sectional area within the equipment.
- Current transformers may not be installed in an area where they block ventilation openings.
- Current transformers may not be installed in an area of breaker arc venting.
- Not suitable for Class 2 wiring method nor intended for connection to Class 2 equipment.
- Secure current transformer and route conductors so that they do not directly contact live terminals or bus.
- External secondary inputs and outputs should be connected to devices meeting the requirements of IEC 60950.
- The following additional requirements apply for recognized board versions of the VerifEye® meter:
 - For use only with listed energy-monitoring current transformers.
 - Associated leads of the current transformers shall be maintained within the same overall enclosure.
 - Unless the current transformers and their leads have been evaluated for REINFORCED INSULATION, the leads must be segregated or insulated from different circuits.
 - The current transformers are intended for installation within the same enclosure as the equipment. These may not be installed within switch gears and panel boards or similar.
- Use this device with **copper or copper-clad wire only**.
- For indoor use only.

2 INTRODUCTION

The VerifEye® 7000 Series meters monitor the voltage, current, power, energy, and many other electrical parameters on single and three-phase electrical systems. A VerifEye® meter uses direct connections to each phase of the voltage and current transformers to monitor each phase of the current. Information on energy use, demand, power factor, line frequency, and more are derived from these voltage and current inputs.

Each of these meters are not meant to be standalone energy recorders; rather they are connected as client devices to a data logger, Remote Terminal Unit (RTU), or Building Management host network. The VerifEye® meter communication interfaces include Ethernet (LAN), or RS-485 serial. BACnet MS/TP and Modbus RTU are the two communication protocols that operate over an RS-485 serial network and BACnet IP and Modbus TCP are supported over Ethernet. A USB port is also provided as the preferred connection for on-site configuration and can be run concurrently with an RTU.

2.1 Unpacking the Unit

You can order the VerifEye® meters with optional product features, which are identifiable on the part number label.

VerifEye® Part Numbering Scheme

70D48-xxx Series 7000 Embedded Branch Circuit Monitor, Mounting Plate, 48 Input, with LCD Display

71C48-xxx and 71D48-xxx Series 7000 Branch Circuit Monitor, Plastic Enclosure, 48 Input, with LCD Display

70D24-xxx Series 7000 Embedded Branch Circuit Monitor, Mounting Plate, 24 Input, with LCD Display

71C24-xxx and 71D24-xxx Series 7000 Branch Circuit Monitor, Plastic Enclosure, 24 Input, with LCD Display

70D12-xxx Series 7000 Embedded Branch Circuit Monitor, Mounting Plate, 12 Input, with LCD Display

71C12-xxx and 71D12-xxx Series 7000 Branch Circuit Monitor, Plastic Enclosure, 12 Input, with LCD Display

70D03-xxx Series 7000 3-Phase Meter, DIN Rail Mount Plastic Enclosure, with LCD Display

71C03-xxx and 71D03-xxx Series 7000 3-Phase Meter, Wall Mount Plastic Enclosure, with LCD Display

Each VerifEye® meter shipment also includes the items below:

- Meter with Options Installed – Serial Number, MAC ID, and FCC ID indicated on side label
- Pluggable Connectors (voltage, three-position terminals for CT, two-position terminals for I/O)
- Thumb drive containing VerifEye® Power Meter Viewer Utilities Software, Register List, Manual, Tutorial Videos
- Certificate of Calibration (COC) for each unit

2 INTRODUCTION

2.2 Meter Anatomy

All user connections are made on the circuit board. Connectors are identified by function and include polarity markers.

Cat. 71x12 Series 7000 Branch Circuit Monitor, Plastic Enclosure 12 Input, with LCD Display

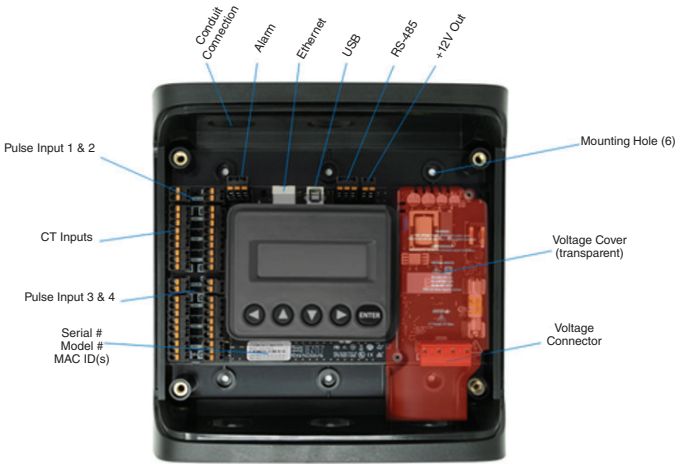

Cat. 70D48 Series 7000 Embedded Branch Circuit Monitor, Mounting Plate 48 Input, with LCD Display

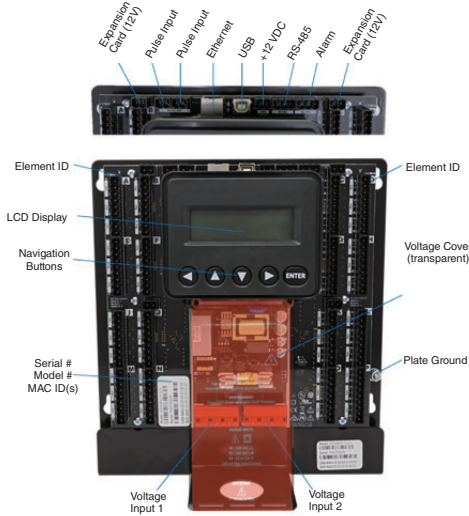

2 INTRODUCTION

71x03 Series 7000 3-Phase Meter, Wall Mount Plastic Enclosure, with LCD Display

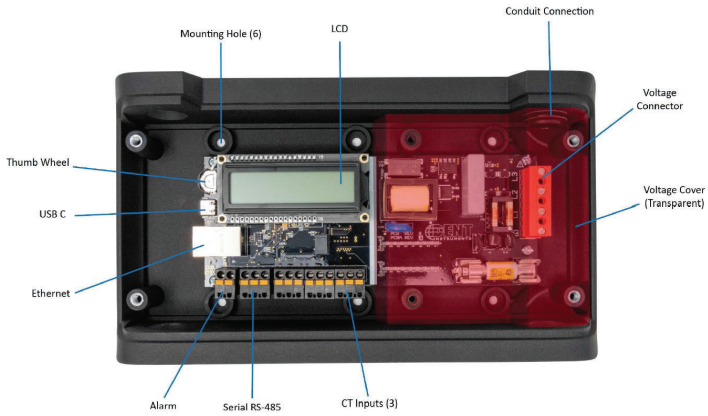

70D03 Series 7000 3-Phase Meter, DIN Rail Mount Plastic Enclosure, with LCD Display

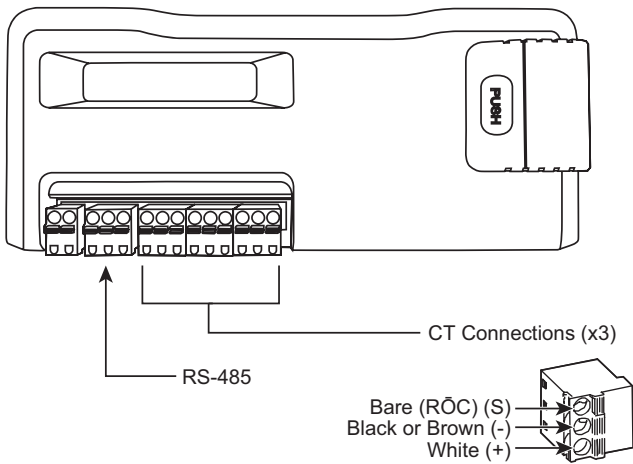

3 PLANNING FOR FIELD INSTALLATION

3.1 Project Manager Aspects

Meter installation often includes coordination between individuals or groups of people with different responsibilities. Spend a few minutes considering who will be executing each portion of the installation and what tools are needed at each stage. Things to consider include determining how to communicate with the meter, setting address configuration, installing Power Meter Viewer Utilities, access to PIN numbers, etc. The more tasks completed before installation the fewer tasks will be needed in the field. The following section gives an overview of typical process activities followed by details in the next section.

3.1.1 Configuration & Data Viewing Options

The VerifEye® meter has three methods for configuration and data viewing. The most powerful interface is a Microsoft Windows application (Power Meter Viewer Utilities) that runs on PCs or tablets. Power Meter Viewer Utilities is encouraged for complex installations and is required for configuring advanced functions like alarms. The second interface is the VerifEye® Web App and is intended for smart phones or tablets that can connect over USB, or Ethernet. The third interface is an optional LCD display which is intended for intermittent end-user observation and is restricted in capability. The RTU can also be used for configuration if communication settings are already established. The feature set of each interface is summarized next.

3.1.2 Information Access by Interface Type

Interface Options	PC or Laptop Running Power Meter Viewer Utilities	Smart Device or Tablet via VerifEye Web App	LCD on Meter (If Equipped)	RTU (Host System) Modbus/ACnet
When	Meter Setup Field Visit	Field Visit	End User	Building System
Real Time Values	All Meter Parameters Waveform Capture Harmonic Analysis All Element View Phasor Plot Alarms	All Meter Parameters Multi-Element View	Voltage Current VA VAR kWh Single Element View	All Meter Parameters
Configuration	Entire Meter Visual Guides Copy/Paste	Entire Meter Text Based	Communications Only	Entire Meter Register Based
Security PINs	Factory Support – Level 3	Read Only - Level 1* Read/Write - Level 2*	Read Only – Level 1* Read/Write Level 2* (limited to communication)	Factory Support – Level 3

* If PINs are configured

3 PLANNING FOR FIELD INSTALLATION

3.2 Meter Configuration Overview

Work performed prior to installation saves time, and may result in fewer mistakes.

Tools	Typical Work
<ul style="list-style-type: none">• Desktop or Laptop PC• USB Type AB Cable (preferred), Ethernet and USB wall charger (> 500 mA), or USB Type C Cable.• Thumb Drive (Power Meter Viewer Utilities Installer) or access www.Leviton.com, and go to software downloads for this product.• Electrical schematics of project	<ul style="list-style-type: none">• Install Power Meter Viewer Utilities Software• Connect USB/Ethernet cable from PC to meter• Establish communication with meter• Firmware update (if required)• Configure software for anticipated meter setup• Field wiring documentation

3.3 Meter Installation Overview

Performed by licensed electrician.

Tools	Typical Work
<ul style="list-style-type: none">• Mounting hardware (customer supplied)• Wiring, supplies, labels, and wire ties• Tablet, Smart Device, or Laptop PC• Multi Meter, Current Clamp• Camera	<ul style="list-style-type: none">• Mechanical mounting• Electrical installation• Install voltage cover• Apply power to meter• Confirm basic operation of meter

3.4 Verification and Communication Overview

Can be modified when you apply power to the meter.

Tools	Typical Work
<ul style="list-style-type: none">• Tablet, Smart Device (Web Page Based), or Laptop PC (Power Meter Viewer Utilities Software)• On-site troubleshooting• Multi Meter, Current Clamp• Camera	<ul style="list-style-type: none">• Locate the power meter• Confirm RTU device• Add wire terminations (if required)• Confirm meter communication settings• Meter health metrics (check for setup errors)• Analytics (Power Meter Viewer Utilities)• Correct instrumentation• Set security PINs• Checklist

3.5 RTU Programming and Scripting Overview

Tools	Typical Work
<ul style="list-style-type: none">• Laptop PC (Remote Access to RTU)• Remote troubleshooting• Register List	<ul style="list-style-type: none">• Confirm meter communication settings.• Confirm communication protocols.• Exercise remote connectivity.• Run configuration scripting.• Confirm data integrity.

4 METER CONFIGURATION

This section describes how to set up the VerifEye® meter in an office environment, and configure the power meter for a pre-determined configuration. The setup is standardized for an organization or project; however, you can document and e-mail the setup to an installer. The setup can also be performed on-site, and reflect “as-built” configurations.

The Power Meter Viewer Utilities application offers visual guides and context help to facilitate meter configuration. Please see the **Power Meter Viewer Utilities** overview section for additional information. By default, VerifEye® meters are configured for DNS Ethernet addressing. A common configuration sequence is to use USB to configure a meter for Ethernet communications at a static IP address, then switch from USB to Ethernet to locate it. To facilitate this, select **[Refresh Connectivity]** on the Power Meter Viewer Utilities software screen.

4.1 Install the Power Meter Viewer Utilities Software

Insert the Power Meter Viewer Utilities thumb drive into the computer or download it from the Leviton FTP site (qualified Leviton personnel only). The installer starts automatically. If it does not, browse the thumb drive and locate the Setup.exe program, double-click it, and follow the installer instructions.

For Custom Installation

For users who want to specify the location of the Power Meter Viewer Utilities software and support files, double-click the **[supportfiles]** folder, and run setup.exe. This prompts the user for additional details.

Name	Date modified	Type	Size	8 items
bin	4/20/2018 8:54 AM	File folder		
license	4/20/2018 8:54 AM	File folder		
Local	4/20/2018 8:54 AM	File folder		
LVRTE	4/20/2018 8:54 AM	File folder		
supportfiles	4/20/2018 8:54 AM	File folder		
midistid	4/17/2018 10:51 AM	ID File		
setup.exe	4/17/2018 10:51 AM	Application	1,40	
setup.ini	4/17/2018 10:51 AM	Configuration sett...		

4.1.1 Connection and Configuration Options Using Power Meter Viewer Utilities

When you launch the Power Meter Viewer Utilities application, it prompts the user to select one of four connectivity options.

- Connect over USB cable.
- Connect over Ethernet to a Predetermined IP address.
- Scan Network.
- Create Setup file only (no meter connected).

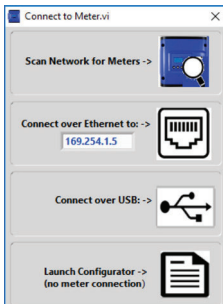

NOTE: The USB connection method is recommended for new users who have physical access to the meter using a USB cable.

4 METER CONFIGURATION

4.1.2 USB Connection (Power and Communications)

1. Connect the VerifEye® meter to a USB port on your computer to provide both power and communications.
 - a. If equipped, the LCD display is the most visible indication of a running meter.
 - b. For meters without a display, a green flashing LED on the circuit board indicates that the VerifEye® meter booted up and is running.
- CAUTION:** The VerifEye® meter draws 450 mA from the USB port. Be sure the USB host is industry standard; otherwise, overloading may occur. If the meter fails to power or flickers when powering over USB, you must use an alternate configuration for power.
2. Launch the Power Meter Viewer Utilities application and select **[CONNECT OVER USB]** in the pop-up window.

The meter starts to communicate.

4.1.3 Ethernet Network Connections

To configure the meter over Ethernet requires a secondary power connection. The meter does not support Power Over Ethernet (POE). If the meter is already installed within the buildings electrical network, closing the AC breaker (or approved disconnect) turns ON the meter through the meter's internal power supply.

NOTES:

- If a computer's USB port cannot provide 500 mA of current, you can use an AC/USB charger or a USB battery as a power source for Ethernet communications.
- Both the **Network Scan** and **Connect Over Ethernet to IP** options require that a valid network connection exists between the VerifEye® meter and configuration PC.



4.1.4 Dynamic Host Configuration Protocol (DHCP):

VerifEye® meters ship in the DHCP mode to prevent IP conflicts with other equipment. The meter expects to receive an IP address from a DHCP service provided by a router, Layer 3 switch, or a server providing DHCP service. Therefore, if the VerifEye® meter and the host PC request an IP address from the same DHCP service provider, they can communicate. When the VerifEye® meter powers up, the IP address is shown on the LCD display (if equipped), or can be found using the Network Scan function.

4 METER CONFIGURATION

4.1.5 Direct Connection

When a PC is directly connected to a VerifEye® meter via an Ethernet cable, no DHCP service exists. This configuration can be made to work, but requires changes to either the meter communication settings or the PC network configuration.

LCD Display

For units equipped with an LCD display, navigate to **Communications > Ethernet Settings > DHCP > OFF**.

Change the IP address in the meter to match the subnet of your PC's IP address, which makes the meter's IP address unique. You can also note the current address on the meter and prepare to configure your PC's IP settings as shown below.

Go to PC's Control Panel

- > Network and Sharing Center
- > Change Adapter Settings
- > Properties
- > Internet Protocol Version 4 (TCP/IPv4)
- > Properties

Use the following IP address:

IP address:	192 . 168 . 1 . 100
Subnet mask:	255 . 255 . 255 . 0
Default gateway:	. . .

Change Computer **IP Address** and **Subnet Mask** to **192.168.1.100** and **255.255.255.000** respectively.

Once the PC and VerifEye® meter are set to communicate on the same IP subnet:

1. Launch the Power Meter Viewer Utilities application and enter the IP address of the meter (shown as the factory default).
2. Select [**Connect over Ethernet to:**] in the pop-up window.

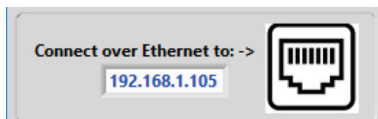

The meter starts to communicate.

For more information on configuring the meter, see the Power Meter Viewer Utilities overview section.

4 METER CONFIGURATION

4.1.6 Network Scan

Network Scan is a feature for monitoring previously installed and configured VerifEye® meters over an Ethernet network. Network Scan broadcasts a UDP discovery packet on the same network as the PC that runs the Power Meter Viewer Utilities application. Normally, this is performed on a corporate network running DHCP. Any VerifEye® meter that responds is displayed in a table that includes the system description register, IP address, serial number, and communication configuration.

Meter	IP Address	Serial Number	MAC Address	Modbus Port	BACnet Port	Mode	Device ID	OK
SERIES 7100	182.168.233.150	P481807002	00:00:c3:31:10:3C	502	47808	Modbus	527000	Cancel
								Rescan
								Test
								Setup

Highlight the desired meter, and select **OK**, **Test** or **Setup**. Note that the effectiveness of this technique is highly dependent on the configuration of the PC running Power Meter Viewer Utilities (which may have more than one network card) and the network configuration. Select **Rescan** to make multiple attempts to locate a particular meter on busy networks (UDP has no built-in retry provisions).

4.1.7 Launch Configurator

The final option in the Power Meter Viewer Utilities Connect to Meter pop-up window is **Launch Configurator**. This option allows you to create a meter setup or alarm table for future use without connecting to a meter. After prompting the user for a meter model, the Power Meter Viewer Utilities application launches under a mode with restricted functionality. This mode operates on files only.

4 METER CONFIGURATION

4.2 Power Meter Viewer Utilities Software Overview

Power Meter Viewer Utilities is a Windows application, and is used to configure and verify a VerifEye® meter. All functions and menus are accessed under the central drop-down list, which has a content filter for viewing **Basic** metering data or **Extended** meter data that can be helpful in troubleshooting. The information displayed in the drop-down list for each filter setting is summarized below.

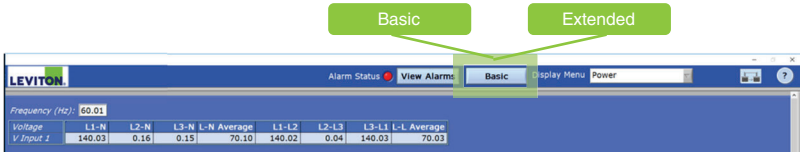

Display Data		Basic	Extended
Monitor	Power	a	a
	Energy	a	a
	Demand	a	a
	Power Factor		a
	Waveform Capture		a
	Harmonics		a
	Phasor Plots		a
Meter Setup	Communication Setup	a	a
	Alarms		a
	Advanced	a	a
	About the Meter	a	a

4 METER CONFIGURATION

4.2.1 Configuring Electrical Components Using Power Meter Viewer Utilities

1. Navigate to **Meter Setup** under the **Display Menu** List Box.
2. Enter a **System Description** for the physical location of the meter.
3. Enter **Element Description** (defaults are A, B, etc.).
4. Select the **Voltage Input** (voltage connector 1 or 2) - for 24 and 48 input models only.
5. Select the **Voltage Multiplier** (optional).
6. Select the **Service Type** (3-Phase 4-Wire, etc.).
7. Select **CT Type** ((CDVxx, CTVxx, CRV50, etc.).
8. Set **CT Multiplier** (optional).
9. Set **CT Flipper** (optional).
10. Repeat steps 3 - 7 for each **Element**.
11. Click **SEND SETUP TO METER**.

4.2.2 Configuring RS-485 Communications Using Power Meter Viewer Utilities

If planning to setup communication via RS-485, follow the steps below:

1. Navigate to **Communication Setup** under **Display Menu** List Box.
2. Select **RS-485**.
3. Select either **Modbus** or **BACnet**.

If you selected **Modbus**, set the following:

- Serial Settings
- Set Modbus Address

If you selected **BACnet**, set the following:

- Serial Settings
- Device ID
- MS/TP Address
- Max Masters (optional)
- Max Info Frames (optional)

4. Click **SEND SETUP TO METER**.

4 METER CONFIGURATION

4.2.3 Configuring Ethernet Communications Using Power Meter Viewer Utilities

If planning to setup communication via Ethernet, follow the steps below.

1. Navigate to **Communication Setup** under the **Display Menu** List Box.

2. Select **Ethernet**.

3. Select either **Modbus** or **BACnet**.

4. If you selected **Modbus**, set the following:

Modbus Port (optional)

If you selected **BACnet**, set the following:

- Device ID
- BACnet Port and BBMD

5. Select either **DHCP** or **Static IP**.

6. If you selected **DHCP**, proceed to the next step.

If you selected **Static IP**, set the following:

- Static IP Address
- Subnet Mask
- Gateway Mask
- Default Gateway

7. Click **SEND SETUP TO METER**.

4 METER CONFIGURATION

4.2.4 Configuring Alarms in Power Meter Viewer Utilities

You can access Alarm settings with Power Meter Viewer under the "ALARMS SETUP" drop-down list and select the "Extended" filter option in the title bar.

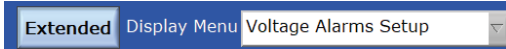

Integer Values

You can enter Integer Values for Voltage Input 1 (3 and 12 circuit meters) and Voltage Input 2 (24 and 48 circuit meters) for L-N and L-L voltage measurements. Alarms are activated by toggling the "Enable" button for each voltage reference independently and by pressing the "Send to Meter" button.

An example of a 10% drop in a 480VAC Delta System is shown below. Only Line to Line measurements are enabled.

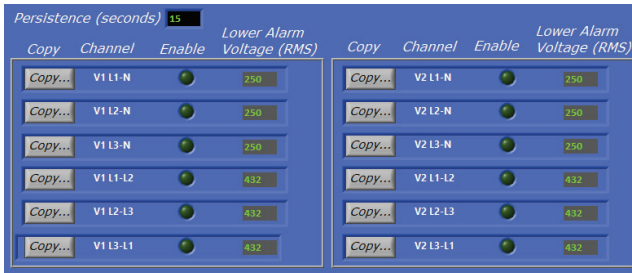

Persistence (seconds) 15				Lower Alarm Voltage (RMS)				
Copy	Channel	Enable	Lower Alarm Voltage (RMS)	Copy	Channel	Enable	Lower Alarm Voltage (RMS)	
Copy...	V1 L1-N	<input checked="" type="checkbox"/>	250	Copy...	V2 L1-N	<input checked="" type="checkbox"/>	250	
Copy...	V1 L2-N	<input checked="" type="checkbox"/>	250	Copy...	V2 L2-N	<input checked="" type="checkbox"/>	250	
Copy...	V1 L3-N	<input checked="" type="checkbox"/>	250	Copy...	V2 L3-N	<input checked="" type="checkbox"/>	250	
Copy...	V1 L1-L2	<input checked="" type="checkbox"/>	432	Copy...	V2 L1-L2	<input checked="" type="checkbox"/>	432	
Copy...	V1 L2-L3	<input checked="" type="checkbox"/>	432	Copy...	V2 L2-L3	<input checked="" type="checkbox"/>	432	
Copy...	V1 L3-L1	<input checked="" type="checkbox"/>	432	Copy...	V2 L3-L1	<input checked="" type="checkbox"/>	432	

Lower Voltage Alarm Values

Lower Voltage Alarm values can be copied to other voltage references by pressing the "Copy" button. This brings up a dialog box and allows the user to select which references to copy.

The maximum value that you can enter into L-N voltage references is 350V and the maximum value that you can enter into L-L voltage references is 600V. Attempting to enter a higher value in these fields may result in the software setting each field to its maximum value.

The Alarm Persistence field is user-configurable, and the time can be adjusted from 15-60 seconds. The alarm condition must be continually expressed for the persistence time to trigger the alarm. This behavior helps reduce false positives on momentary voltage changes or events that cause the meter to reboot, such as changing communication settings.

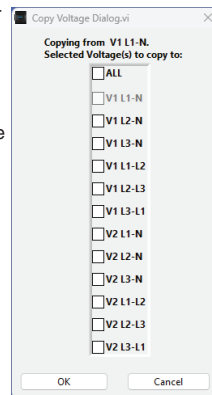

4 METER CONFIGURATION

Indicator Status

If no alarms are enabled, the indicator remains dark.

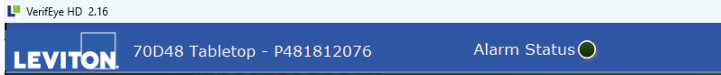

If an alarm is enabled but not triggered, the indicator will be bright green.

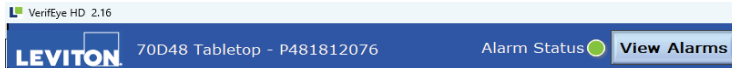

A triggered alarm causes the Alarm Status indicator at the top of the Power Meter Viewer to turn red.

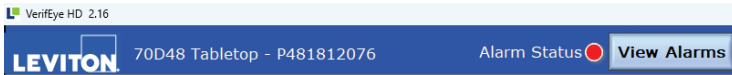

Host systems are notified of an alarm via a hardware circuit (normally low) that can be wired to an interrupt input. Details about which alarm triggered are determined by reading the status registers under the alarm block 2450 – 2500.

The alarm will be expressed whenever the condition exists and will clear itself if measured values exceed the trigger points. Alarm conditions are evaluated by the meter once per second.

4 METER CONFIGURATION

4.2.5 Setting the Real Time Clock

The VerifEye® meter includes a **Real Time Clock**. The clock is used only to time stamp Interval Data in the log. It is not used for calculation within the meter. For those customers using the IDR function of the meter, it is helpful (but not necessary) to set the real time clock so that data records can be uniquely identified. The time can be set using Power Meter Viewer Utilities, under the **Advanced Tab**, by clicking on the small time icon in the bottom-right corner of the clock.

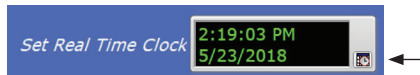

The clock icon launches the **Window Calendar** and allows the user to choose the desired date and time. Click **Set Time to Now** to populate the current time. Click **OK** to commit this time to the RTC chip onboard the meter.

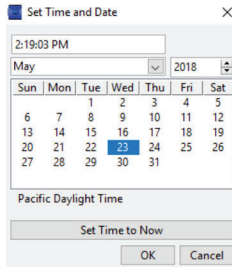

Real Time Clock Power Source

The RTC integrated circuit is a stand-alone low power circuit within the VerifEye® meter. Time is kept in the absence of a connected external power source (AC or USB power) by a super capacitor. The capacitor can keep the RTC running over normal power outages (days to weeks), but it does not keep time while the meter is stored or shipped.

NOTE: It is recommended that users use the **Interval Data Recording** capability of the VerifEye® meter to ensure the **Real Time Clock** is set as part of the commissioning process.

4 METER CONFIGURATION

4.2.6 Retrieving Interval Data

The VerifEye® meter maintains an internal log of the energy data (Net kWh) for each channel in the meter. This log updates every 15 minutes, and is always active. The meter stores 63 days' worth of 15 minute data in its memory. A user can retrieve this data to restore gaps in data collection when RTUs were offline or communication was interrupted. You can access Interval Data Recording (IDR) through Power Meter Viewer Utilities in the **Advanced menu**.

Click **Download**



A screenshot of a software interface showing a blue button labeled "Download" on the left and a white text input field on the right. Above the text field, the text "Path to logged data file (.csv)" is displayed in a smaller font.

By default, the name of the data file includes the Serial Number of the meter and the System Description followed by – Datalog.

Click **OK** to display the entire data path.



A screenshot of a software interface showing a blue button labeled "Download" on the left and a white text input field on the right. Above the text field, the text "Path to logged data file (.csv)" is displayed in a smaller font. The text field contains the path: "C:\Users\User Name\Documents\S7ConfigurationUtilities\P12365498710 Meter Name.csv".

The data log is a Comma Separated Values (CSV) file that can be opened in Excel or another program. The data is listed in chronological order according to an internal 32-bit sequence counter. The sequence counter can be used to merge separate files together, if necessary.

EXAMPLE:

Sequence Number	Time Stamp	A1 kWh	A2 kWh	A3 kWh	A System	B1 kWh...
123456	5/15/2022 12:00	1.11E+5	2.22E+5	3.33E+5	6.66E+5	0
123457	5/15/2022 12:15	1.12E+5	2.23E+5	3.34E+5	6.69E+5	0

4 METER CONFIGURATION

4.3 VerifEye® Web App Overview

The VerifEye® meter hosts a Web Application that can be accessed by any smart device running a web browser. You can access the VerifEye® Web App via the USB or Ethernet port.

NOTE:

- Mac users can configure the meter using the VerifEye® Web App Interface by installing a driver that is included in the media distribution materials.
- The VerifEye® Web App operates on a single element at a time.

4.3.1 Connect to Web App Using USB

1. Connect your smart device to the meter.
2. Open Web Browser.
3. Enter **http://169.245.1.5** in the address bar (this is the static address of the USB port).

4.3.2 Connect to Web App Using Ethernet

1. Discover the IP address of the meter by one of the following methods.
 - Navigate to **About Meter** on the LCD menu.
 - Use a network discovery tool to find the address by connecting and disconnecting the Ethernet cable.
 - Set the meter to a static address using the serial interface.
2. Connect your smart device to the same subnet as the VerifEye® meter.
3. Open a Web Browser.
4. Enter the meter's Ethernet address into the web browser.

4.3.3 Authentication

You can view and control the VerifEye® Web App from any smart device, and it communicates in parallel to the host system, therefore, the meter can be configured to require a PIN to restrict access to it.

Enter the PIN, if assigned, or leave blank, if unassigned, and click **LOGIN**.

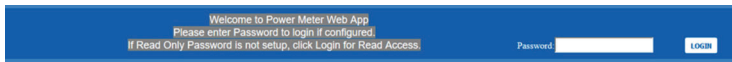

Welcome to Power Meter Web App
Please enter Password to login if configured.
If Read Only Password is not setup, click Login for Read Access.

Password: **LOGIN**

5 METER INSTALLATION

This section describes the physical installation of the meter and provides guidance on connecting the current transformers (CTs) correctly within the electrical load center and to the VerifEye® meter.

5.1 Meter Mounting Configurations

VerifEye® meters are sold in several form factors. Enclosures are designed to be wall mounted and connected to electrical conduit. Plate mounted versions are ready to be mounted inside a customer supplied NEMA enclosure.

CAUTION: Be careful not to flex the circuit board during mounting.

Enclosure

Cat. 71x12



Cat. 71x48 and 71x24



Plate Mounted

Cat. 70D12



Cat. 70D48 and 70D24



5 METER INSTALLATION

5.2 Installation Sequence

For enclosure models only.

1. Remove covers.

Screws are provided.

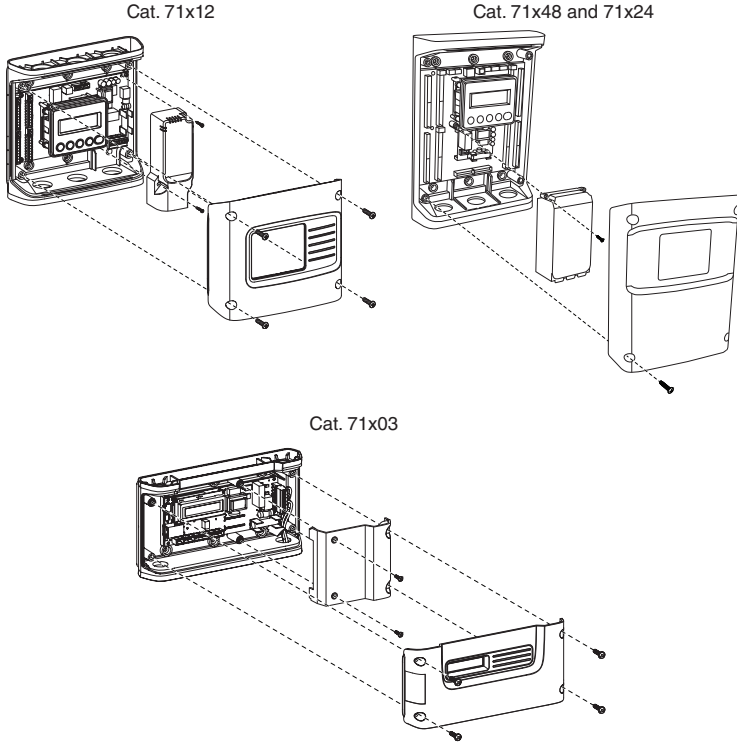

5 METER INSTALLATION

2. Mount.

Use the enclosure as a template.

NOTE: If meter is not available to use as a template, see the mechanical specifications drawing in the appendix.

Cat. 71x12

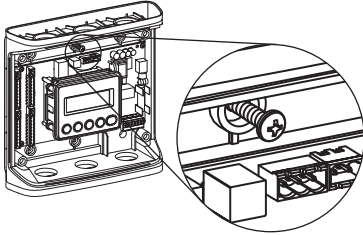

Cat. 71x48 and 71x24

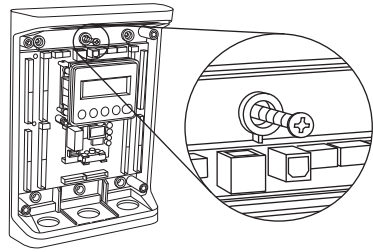

Cat. 71x03

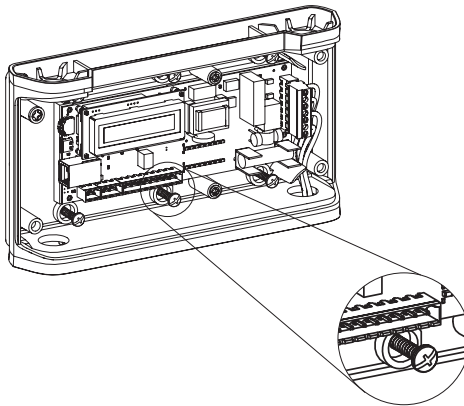

5 METER INSTALLATION

3. Connect.

- Conduit fittings
- Conduits
- Blanking plugs

Cat. 71x03

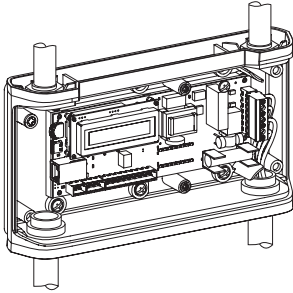

Cat. 71x12

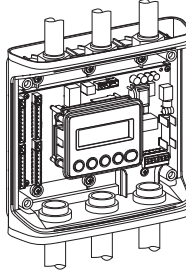

Cat. 71x48 and 71x24

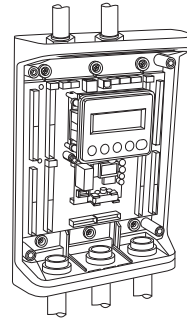

4. Connect voltage leads.

WARNING: RISK OF ELECTROCUTION, SHOCK, EXPLOSION, OR ARC FLASH. DO NOT ENERGIZE METER WITH VOLTAGE COVER REMOVED. CAREFULLY READ AND FOLLOW INSTRUCTIONS.

Connect the voltage leads (L1, L2, L3, and N as necessary) to the meter through a dedicated disconnect or circuit breaker.

NOTE: Verify the circuit breaker is marked as the disconnect breaker for the meter.

Wiring the Meter in a Single-Phase Application: The meter is powered through the voltage between L1 and L2. For single-phase installations, where no L2 exists, install a jumper from N to L2. This connection provides power to the meter, maintaining L1-N as the metering voltage reference.

Cat. 71x12

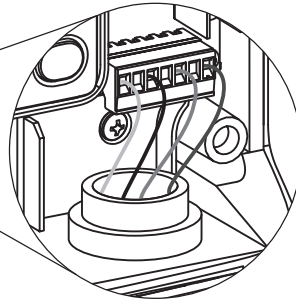
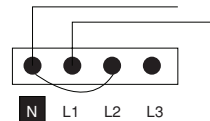
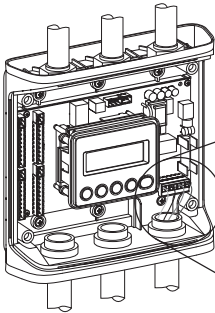

5 METER INSTALLATION

Cat. 71x48 and 71x24

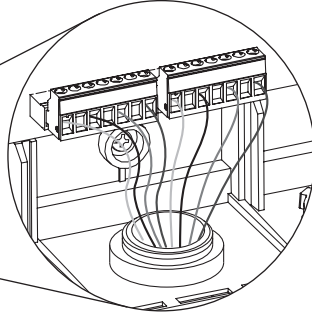
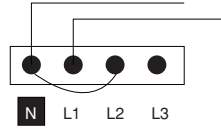
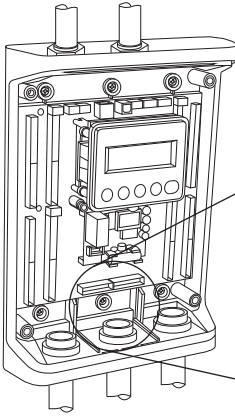

Cat. 71x03

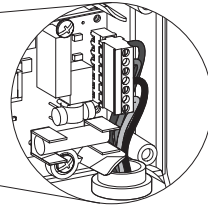
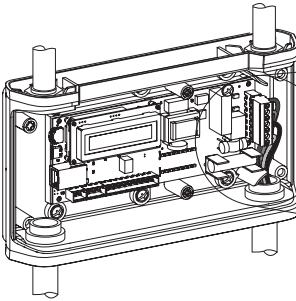

5 METER INSTALLATION

5. Attach high-voltage cover.

NOTE: IP30 TouchSäf (with internal cover installed).

Cat. 71x12

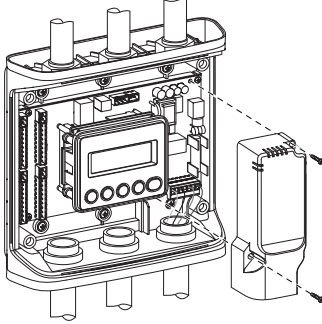

Cat. 71x48 and 71x24

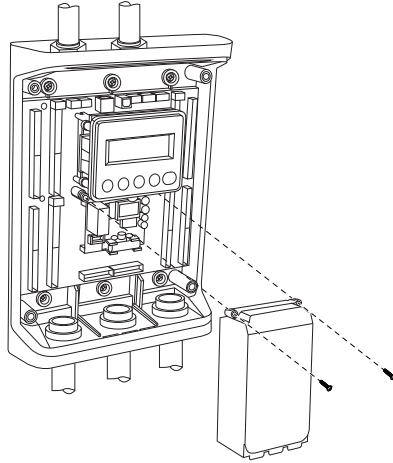

Cat. 71x03

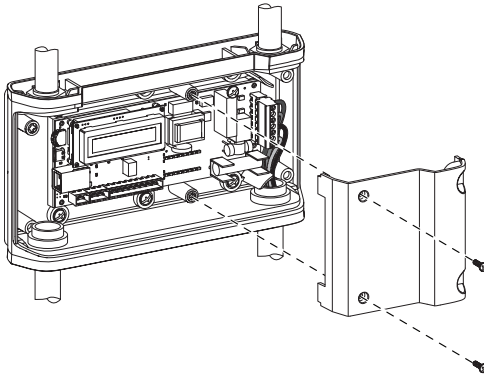

5 METER INSTALLATION

6. Connect CT and communications wiring.

Cat. 71x12

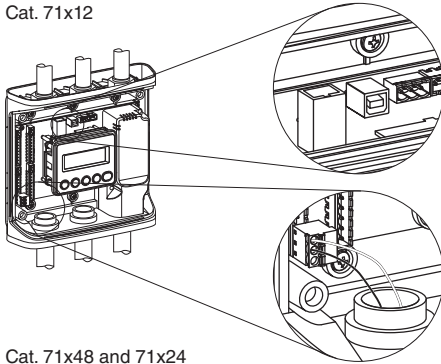

Cat. 71x48 and 71x24

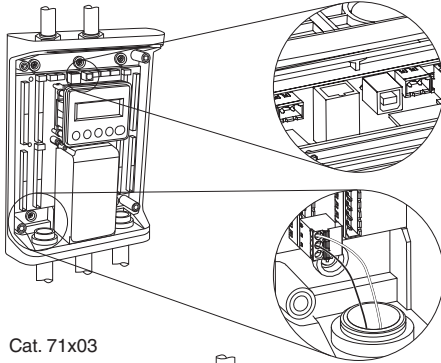

Cat. 71x03

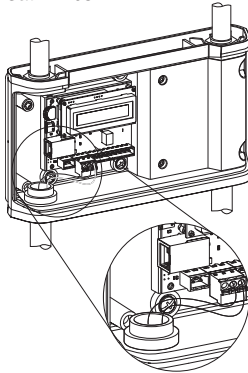

5 METER INSTALLATION

5.3 Installation Sequence for 70D03

This section illustrates the 70D03 model, which is equipped with a built-in DIN rail channel for easy installation. The 70D03 must be installed inside a UL approved electrical enclosure.

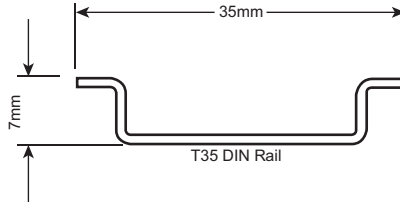

1. Within a suitable UL-approved enclosure, attach a section of T35 DIN rail on which to mount the meter. Leave enough clearance to route voltage, CT, and communication wires within the enclosure. The customer supplies the UL-approved enclosure.
2. Mount the meter on the DIN rail by pressing the top edge of the DIN rail channel on the meter into the top of the DIN rail, and then pushing the meter firmly towards the DIN rail so that it clicks into place. The meter can be released from the DIN rail by using a screwdriver to pull the DIN rail tabs at the bottom of the meter.

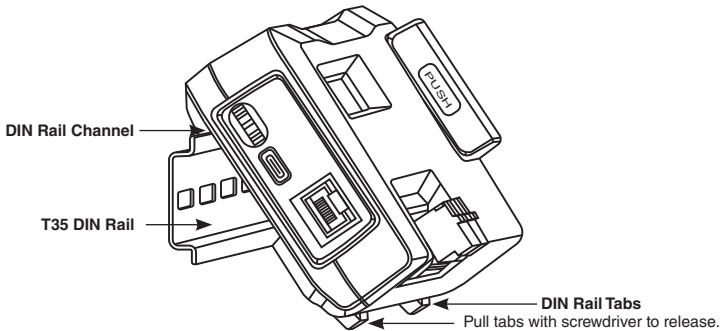

3. Remove the high-voltage cover, and connect the voltage leads to the meter.

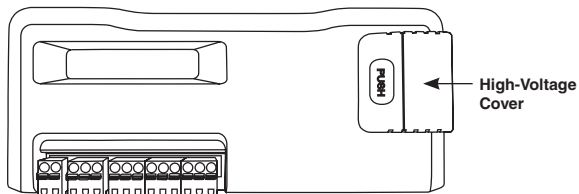

WARNING: DO NOT ENERGIZE METER WHEN VOLTAGE COVER IS REMOVED.

5 METER INSTALLATION

4. Reattach the high-voltage cover.

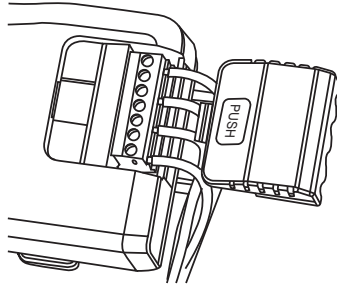

5. Connect CT and communications wires.

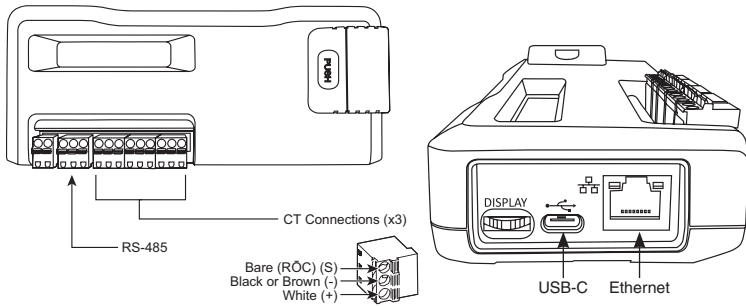

Connecting Voltage

Connect the voltage leads (L1, L2, L3, and N, as necessary) to the meter through a dedicated disconnect or circuit breaker. A voltage lead of 14 AWG THHN minimum 600V AC rating (or equivalent) is required.

NOTE: Verify the circuit breaker is marked as the disconnect breaker for the meter.

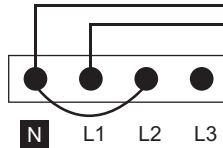

5 METER INSTALLATION

5.4 Wiring in a 3-Wire, Split-Phase Service Panel

WARNINGS:

- **TO AVOID FIRE, SHOCK, OR DEATH; TURN OFF POWER** at circuit breaker or fuse and test that power is OFF before wiring!
- **HIGH-VOLTAGE WIRES MAY BE PRESENT.** To be installed by an electrician or qualified personnel only.

Configurations shown are for service types available in the **METER SETUP** drop-down menu.

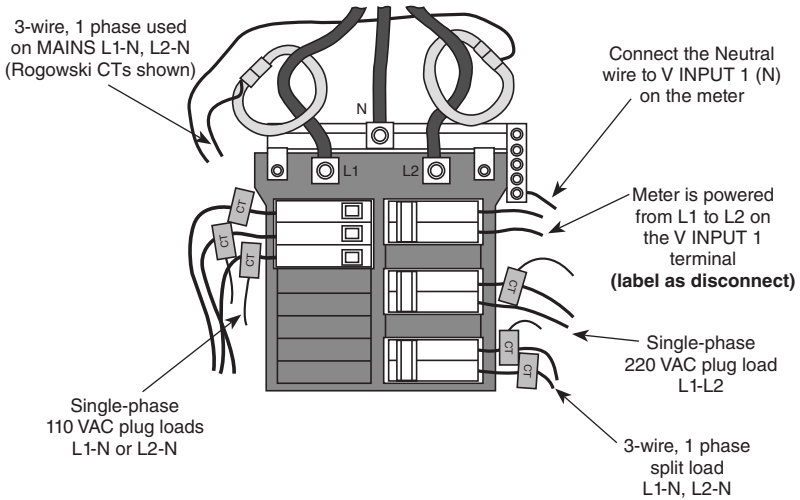

EXAMPLE LOADS:

Single-phase L1-N or L2-N 110 VAC: lighting, appliance, living zone

Single-phase L1-L2 220 VAC: water heater, clothes dryer, equipment with no neutral wire

Split-phase L1-L2 220 VAC: service entrance, equipment with neutral wire

5 METER INSTALLATION

5.5 Wiring in a 3 Phase, 4-Wire Service Panel

WARNINGS:

- **TO AVOID FIRE, SHOCK, OR DEATH; TURN OFF POWER** at circuit breaker or fuse and test that power is OFF before wiring!
- **HIGH-VOLTAGE WIRES MAY BE PRESENT.** To be installed by an electrician or qualified personnel only.

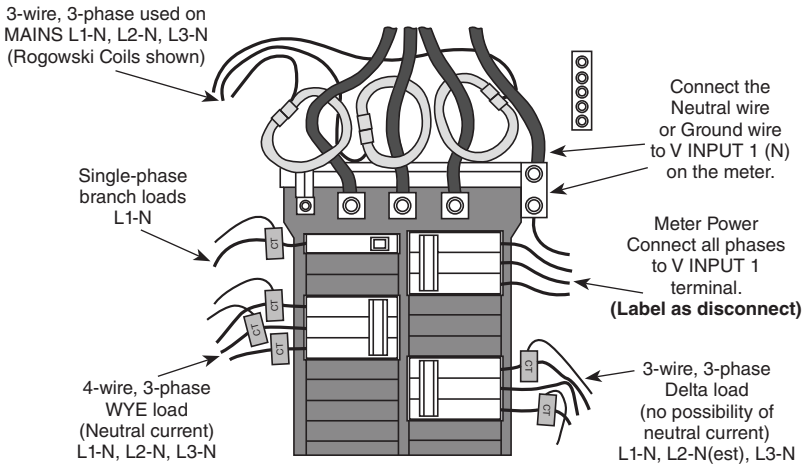

NOTE: The VerifEye® meter uses the NEUTRAL terminal as a voltage reference. For systems without a neutral conductor, it is recommended to connect a ground wire to this terminal. If the neutral terminal is left open, L-L measurements are accurate, but L-N measurements may not be symmetric. If a ground wire is connected to the NEUTRAL terminal, <math><2\text{ mA}</math> flows into the ground wire.

5 METER INSTALLATION

5.6 Current Transformers Basics

1. Ensure CTs meet the following criteria by referring to label on CT:
 - 600 VAC UL rated
 - 1/3 (333 mV) output voltage
 - Appropriate range for the circuits (5-120%) of CT rating recommended
2. Ensure CTs are oriented and placed properly.
 - Arrow points toward load (or as instructed by CT label).
 - Arrow points away from panel (or as instructed by CT label).
 - Place on first conductor of voltage reference. L1-L2 circuits are placed on L1.
 - Observe wiring color and polarity.
 - Use the shield wire, if provided. (Connect to PCB terminal marked S.)



Current Transformers Basics

White: Positive
Black: Negative
(No Shield)



Rogowski CTs

White: Positive
Brown: Negative
Bare Wire: Shield

5 METER INSTALLATION

5.7 Wiring the CTs to the VerifEye® Meter

The image below shows how to connect CTs to the input terminals on the S7000 for each service type. For service types that are not specifically listed, choose SINGLE PHASE service from the drop down menu and configure each channel individually. The three phase loads that are illustrated on the left and split phase loads on the right are shown as examples only. Elements are fully interchangeable on the meter.

NOTES:

- Current and voltage inputs must be installed 'in phase' for accurate readings (e.g., CT1 on Line 1, CT2 on Line 2). **Orientation is critical.** Ensure that all CTs are properly oriented with the line and load, as marked.
- Failure to install CTs in the correct orientation and on the correct phase leads to inaccurate meter readings.

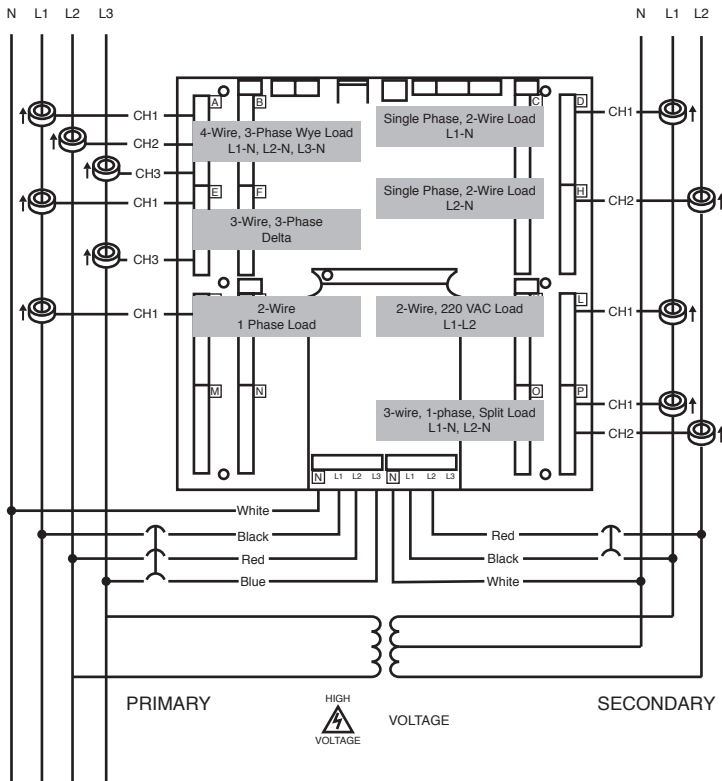

6 COMMUNICATION AND VERIFICATION

This section describes how to commission the meter by an instrumentation technician. You can perform the electrical installation prior to the availability of the RTU; however, the instrumentation technician works with a remote programmer who confirms the connectivity with a remote host system. You can also use a Digital Multimeter (DMM) to confirm measurements at the board's terminals, if necessary.

WARNING: It is assumed that the meter is now powered up from the line voltage. **ONLY IF THE INTERNAL HIGH VOLTAGE COVER IS INSTALLED** is it safe to touch the meter (including the user buttons) with the top cover removed.

NOTE: Communications settings and real-time data values can be confirmed quickly using the LCD interface if equipped. When significant setup modifications are anticipated, a computer interface is recommended.

6.1 Physical Connections on an RS-485 Multi-Drop Network

The VerifEye® meter uses a 2-Wire, Half-Duplex RS-485 implementation.

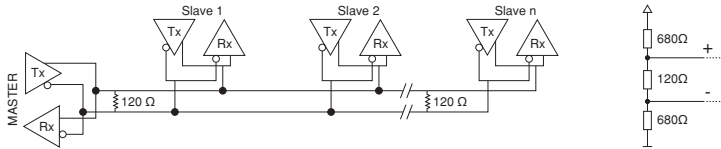

- **Termination Resistors** — These are NOT included on the VerifEye® meter. If the VerifEye meter is at the end of a daisy-chain, then connect a 120 ohm-leaded resistor between the + and – terminal at the connector.
- **Bias Resistors** — These are NOT included on the VerifEye® meter. Bias resistors are needed if the idle conditions of the bus are in an indeterminate logic voltage. Bias resistors are usually located at the master node and are usually 680 ohms on an RS-485 network.
- **Network Topology** — RS-485 is designed to be implemented as a daisy chain (series of connections) rather than star or cascade topologies.
- **Signal Names** — Some RS-485 devices use the terminology A/B while others use +/--. Note that A is (-) and B is (+).
- **Bus Loading** — The VerifEye® meter is 1/8 of a unit load that allows you to connect up to 256 like devices in parallel.

6 COMMUNICATION AND VERIFICATION

6.2 Communication Verification

Verification includes confirmation of BOTH the physical interface settings (Serial or Ethernet) and the protocol (Modbus or BACnet) settings.

Use the LCD's user's interface to quickly confirm the settings required for each combination of interface settings and protocol. The interface is intuitive and groups together commonly associated registers. Arrows indicate how to move from one menu to the next. The active menu item is indicated by a blinking character on the LCD. Press the ENTER button to select a value, and up/down buttons to select the values supported by the meter.

NOTE: Changes to the meter configuration are limited to the communication interface using the LCD. If additional changes, such as CT type, are required, they must be made using a software interface.

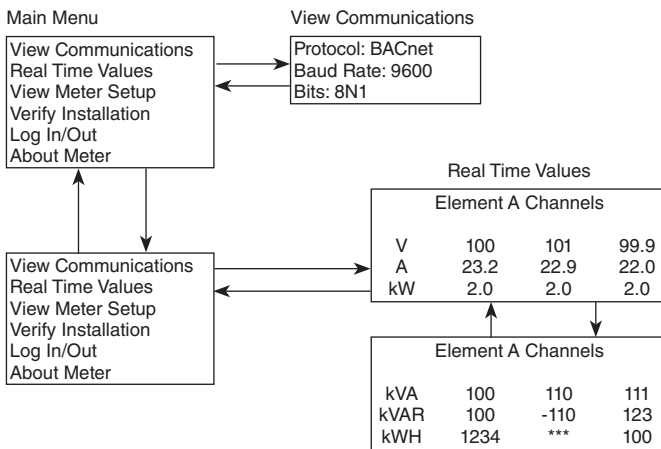

NOTE: A full navigational map is available in **Appendix A**.

Power Meter Viewer Utilities and VerifEye® Web App

If your VerifEye® model does not include the LCD user interface, or if you prefer to verify the installation with software, use the Power Meter Viewer Utilities PC application or the VerifEye® Web App, which shares a common design, to verify communications. Refer to the Configuration Details section for an overview and list of instructional videos for Power Meter Viewer Utilities or the VerifEye® Web App.

6 COMMUNICATION AND VERIFICATION

6.3 Physical Interface Verification

Serial Setup Verification

In a multi-drop serial network, the host data format settings are typically known or specified, and the slave is adjusted to match. If you have long wiring runs, experiment to determine the fastest allowable baud rate for the wiring configuration (change BOTH the host and slave devices). Configurations other than 8N1 are rare, and it is advised to use this configuration for Data Bits, Parity, and Number of Stop bits.

LAN Ethernet Network Verification

The VerifEye® meter uses IEEE 802.3 Ethernet connectivity (running at a 10/100 Mbps) to communicate. Verification of the meter settings over Ethernet includes that the IP address of the meter is within a range that supports communication with a host (if static) or is set for DHCP. This allows the meter to be assigned an address by a DHCP server, as described below.

DHCP

If the VerifEye® meter is configured for DHCP when the meter is powered ON, or the Ethernet cable is inserted, the meter is assigned an IP address by the DHCP server. This address appears on the meter's LCD screen, or found in Power Meter Viewer Utilities software or the VerifEye® Web App. The IP address assigned to the meter is a temporary address, as the address may change between power cycles, which makes it difficult for the host system to find the meter on the network. It is best to configure the meter for DHCP so that the address assigned by a DHCP server can change that IP address to static one when the connection is made. VerifEye® meters are set to use DHCP as a default setting.

Static IP

If the VerifEye® meter is set to a static IP, then its address is assigned by an IT department to avoid multiple devices with the same IP address on the same network. Use static IPs when an RTU expects to find the meter at a specific IP address.

6.4 Protocol Verification

Specify the network protocol when you install the meter. BACnet MS/TP and Modbus RTU are the two communication protocols that operate over an RS-485 serial network and BACnet IP and Modbus TCP are the protocols over Ethernet. Each combination of interface and protocol require specific register settings described in the next section. The scope of this section is to use either the LCD interface or software tools to quickly confirm or change settings to match an existing specification. Further information and optimization tips are covered in the section on RTU programming.

6 COMMUNICATION AND VERIFICATION

6.5 Modbus Settings

Modbus RTU Settings

Device Address: In a Modbus network, each device must be assigned a unique slave address. Valid Modbus addresses are 1-240 (the VerifEye® 48 channel meter requires 15 addresses beyond Element A). The slave address of the power meter sets the register address for Element A. Adjacent elements B, C, and D are accessed by incrementing the slave address by one. The slave address of the VerifEye® meter must be set to match the address expected by the RTU and is part of the network specification. The default address for Element A is 1.

Modbus TCP Settings

Modbus Port: The VerifEye® meter uses the industry standard Port 502 for Modbus, but even though you can change this port number, leave it set to 502, unless it generates a conflict in the host system. If you must change the port number, change it from the Power Meter Viewer Utilities software interface.

6.6 BACnet Settings

BACnet Device ID: In a BACnet network, each device must be assigned a unique Device ID that is common to BACnet MS/TP and BACnet IP protocols. Besides the standard ability to change this from a BACnet explorer tool, you can change it from the Power Meter Viewer Utilities software, VerifEye® Web App, or LCD.

BACnet MSTP

Device Address: VerifEye® meters are Master devices and must use MS/TP addresses in the range from 0-127. These addresses must be unique on the network.

Max Masters: The default setting is 127 and does not need to be changed.

Max Info Frame: The default setting is 1 and does not need to be changed.

BACnet IP

BACnet Port: The BACnet default port is 47808 and does not need to be changed.

BBMD: The BACnet/IP Broadcast Management Device is set to 0.0.0.0 by default, but can be changed through a software tool to allow discovery across networks.

6 COMMUNICATION AND VERIFICATION

6.7 Pulse Inputs

Series 7000 meters are equipped with 2 pulse inputs. Pulse counting supports the accumulation of consumption data from any external meter using a dry contact (Form A Relay) or open collector outputs. The pulse inputs are compatible with "low-speed" meters. The pulse duration must exceed 50 mS in both the logic low- and high-states, which all a maximum input frequency of 10 Hz.

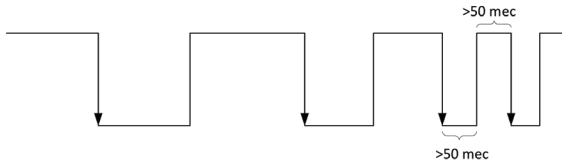
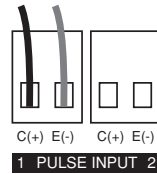

Pulse scaling, resetting, and accumulated values are accessed through registers, and are "system" in scope.

Refer to the register list or Power Meter Viewer Utilities software for more information.

6.8 Alarm Output

The alarm is designed to be connected to an external DC source between 5 and 24 volts and used with a customer-supplied pull-up resistor. A 10k-ohm 1/4 watt resistor is the recommended load for this circuit.

For more information on setting up alarms, see section 4.2.4, "Configuring Alarms in Power Meter Viewer Utilities."

NOTE: The Master Alarm relay is intended for low-voltage DC connections. The user must protect the switch from over-current conditions when closed.

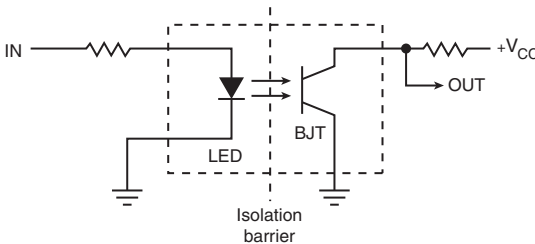

6.9 12 Volt Auxillary Power

The VerifEye® meter provides an auxiliary 12 volt output that is derived from an auxiliary winding on the VerifEye® meter's line-connected power supply. The 12 volt supply voltage is unregulated, but protected by a self-resetting fuse. The purpose of the supply is to power external radio equipment, or provide supply voltage for analog sensors, such as 4-20 mA current loop devices. If full-rated current is drawn from this terminal, the minimum operating voltage of the L1-L2 power supply is 100V AC.

6 COMMUNICATION AND VERIFICATION

6.10 Access Restriction Limitations

If security levels have been set up in the meter, no data is accessible through the LCD user interface or VerifEye® Web App without entering your PIN credentials.

NOTE: Protocols, such as Modbus, do not support any level of security so any network traffic acting as a master can retrieve and write data from the registers. You must have knowledge of the IP address or slave ID and the register list, which discourages casual intrusions.

6.11 Security PIN Protection

VerifEye® meters have two levels of PIN protection that users can choose to assign to restrict access to meter information. The PIN logic is described in the figure below. The default user entry (on power up or time-out) is 0000, which satisfies both the Read Only and the Read/Write default register settings.

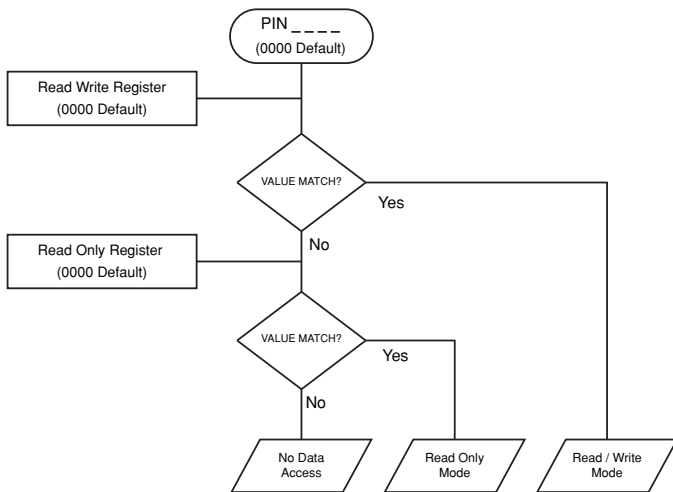

Using the Permission Registers

The VerifEye® meter uses both a Read Only register and a Read/Write register to compare against user entries from the LCD keypad or VerifEye® Web App form entry. Both internal permission registers have a default value of 0000. A consequence of this is that both PIN registers must be configured (i.e., changed from defaults) to implement a read only PIN. If the PINs are not changed, a user who wants to restrict access to Read Only by setting only this PIN may be unaware that the default PIN still matches the criteria for Read/Write, which accidentally promotes the user. The Power Meter Viewer Utilities software and the VerifEye® Web App disallow this condition, but remote programmers who use direct register access, may create this condition.

6 COMMUNICATION AND VERIFICATION

Read Only Permission Register

Configuring the meter for a Read Only user allows data or configuration items to be viewed, but not changed. This level of authorization is appropriate for end-users, such as building owners who may not know the details of the installation. It is recommended to use the Power Meter Viewer Utilities software to configure permissions.

Read/Write Permission Register

Read/Write permissions allow users to read and write configuration items and to reset the PINs. This level of authorization is required by any technician or user who needs to correct setup errors in the meter. The default PIN (0000), allows new users to reset the Read/Write PIN from either the VerifEye® web app or Power Meter Viewer Utilities software.

Reading PINs over Modbus or BACnet

Use the Power Meter Viewer Utilities software to directly report the Read Only and Read/Write PINs under the Advanced Tab (passwords). The value reported by the Power Meter Viewer Utilities software is the value entered on the web page or LCD interface.

PINs are also accessible via registers, but are encoded so that reading the value of the register through an RTU does not give the user the password. This feature allows Leviton Manufacturing to look up forgotten PINs, if network access is available.

Power Meter Viewer Utilities - Unrestricted Access

You can use the Power Meter Viewer Utilities software tool to read and write configuration information to the meter without entering credentials.

NOTE: Power Meter Viewer Utilities software is the recommended tool for setting up access restrictions. It allows users to test the function of the PINs without locking themselves out to change the PIN.

6 COMMUNICATION AND VERIFICATION

6.12 Installation Verification

Once the VerifEye® meter is configured and communicating with the RTU, it is recommended to ensure that all the CTs are on the correct voltage phases and that the CTs face the correct direction. Verify special circuit conditions, such as unloaded motors, which may indicate an installation error when none exists. Use a Digital Multimeter (DMM) to confirm.

6.12.1 Installation Phase Verification

The VerifEye® meter includes a PhaseChek™ algorithm that identifies any element that the meter suspects may be incorrectly phased (i.e., the CT is associated with the wrong voltage source or is physically on the wrong wire) based on power factors below 0.55. Use the LCD interface to access this feature and navigate to **VERIFY INSTALLATION** and press **ENTER**. The LCD display lists the elements that have at least one channel with a low-power factor.

CHECK ELEMENTS

A EF

Use the navigation buttons to highlight a specific element and press ENTER, or press ENTER and move from element to element using the <- / -> keys. Within each element (identified on the top line of the display) the status of each channel is identified as good (PF > 0.55) or bad (PF < 0.55).

ELEMENT F

CH1 Good

CH2 Bad

CH3 Bad

Two "Bad" channels are an indication that two CTs have been swapped. When the power factor for all enabled channels is greater than 0.55, the meter reports:

CHECK ELEMENTS

ALL CHANNELS GOOD

NOTE: PhaseChek is only applied for elements that are enabled. Use **VIEW METER SETUP** on the LCD screen to ensure that all intended elements are active. PhaseChek is advisory only. It is possible that the power factor for a particular load is less than 0.55, as may be observed in a free-running motor.

The Power Meter Viewer Utilities software and the VerifEye® Web App run PhaseChek continuously on all enabled elements and report low-power factor in a real time values table by turning the text red, or by a using a red indicator.

6 COMMUNICATION AND VERIFICATION

6.12.2 Phase Checking by Phasor Plot

When a CT is installed on an incorrect phase, the indicated current vector points either 180 degrees away (a split-phase system) or 120 degrees away (a three-phase system) from the true displacement angle. In the latter case, this usually causes a significant decrease in the reported power factor, even if the CT is also on backwards. When the absolute displacement power factor of a load is below 0.55 (an angle greater than 57 degrees between voltage and current), the VerifEye® meter flags it as a phasing error. The Power Meter Viewer Utilities software has a Phasor Plot feature that can be used to study the voltage and current vectors of a meter element.

Check for Low-Power Factor

- **Power Meter Viewer Utilities Software:** Real Time Values > (All power factors < 0.55 are shown in Red).
- **VerifEye® Web App:** Real Time Values > (All power factors < 0.55 are shown in Red).
- **LCD:** Verify Installation > (LCD lists all elements that have a PF < 0.55).

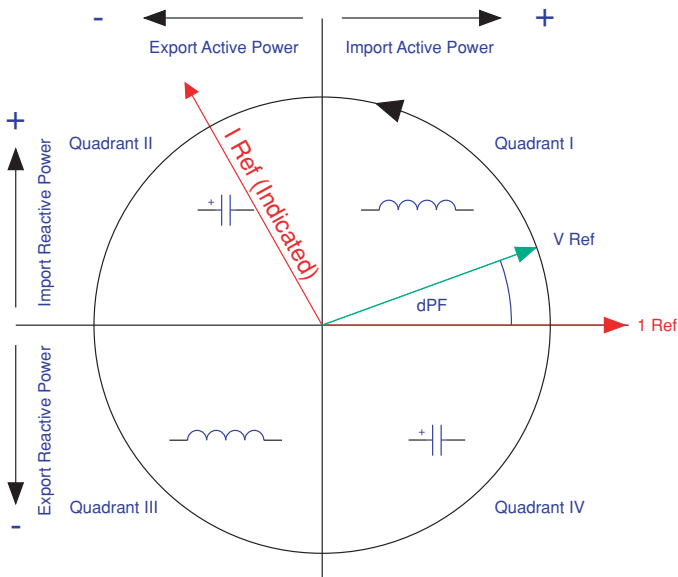

Electrical Power Quadrants with Incorrect CT Phase

6 COMMUNICATION AND VERIFICATION

6.12.3 CT Orientation Check

The VerifEye® meter reports power and energy in each electrical quadrant under a different register. When CTs are installed backwards, the indicated current vector is oriented 180 degrees away from the true displacement angle. According to standard definitions, the wattage and VARs of the effected channel, report with a sign opposite from what is expected. This means that the import registers read zero, while the export registers show a value.

NOTE: Backward CTs have no impact on the amplitude of the power factor. A moderate power factor (>0.7) with a negative power shows that the CT is on backwards, but is on the correct phase. If a CT is on backwards after the installation is complete, you can reverse the direction of the CT via a user configuration register called the Flipper (located at 2226, 2234, and 2235), or use the meter setup feature in the Power Meter Viewer Utilities software.

Check that the wattage has the correct sign (designated + for loads)

- **Power Meter Viewer Utilities software:** Real Time Values > (Confirm Sign of Power for All Elements)
- **VerifEye® Web App:** Real Time Values > (Confirm Sign of Power for All Elements)
- **LCD:** Real Time Values > (Confirm Sign of Power for All Elements)

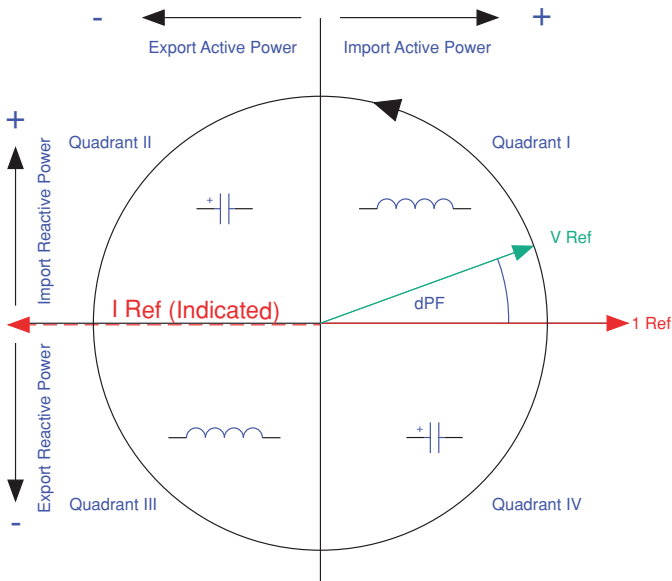

Electrical Power Quadrants with Reversed CT Phase

6 COMMUNICATION AND VERIFICATION

6.13 Power Factor Convention

Power Factor is the ratio of a signed number (true power) and an unsigned number (apparent power). The VerifEye® meter allows users to select between two conventions (ANSI and IEEE). In the IEEE convention, the PF sign follows the sign of power itself. In the ANSI convention, a [+] PF indicates a lagging current (inductive load), while a [-] PF indicates a leading current (capacitive load). The sign relationships are shown below for these conventions in each electrical quadrant.

P.F.	Q1	Q2	Q3	Q4
ANSI	+	-	+	-
IEEE	+	-	-	+

6.14 Total Harmonic Distortion

The Verifeye® meter reports overall harmonic content in power (% T) based on its measurement of Power, Var and Apparent Power as illustrated in the figure below. This method only provides the overall harmonic content.

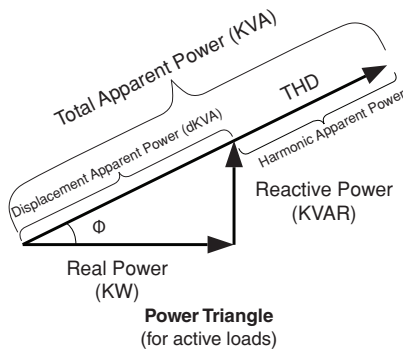

If the voltage is sinusoidal, the T measurement is a good estimate of both power and current. However, if the voltage waveform is distorted, the reported T in power can be misleading. The Power Meter Viewer Utilities software provides additional analysis of harmonic content in voltage and current by sampling the raw data and performing digital signal processing. Using this method, the individual harmonic levels can be observed. The results are presented in a bar graph, as shown below.

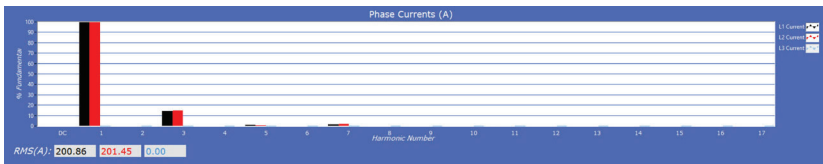

6 COMMUNICATION AND VERIFICATION

6.15 Pre-Processing Aids

The meter has several registers that can aid in pre-processing or post-processing data that may need secondary operations.

Snap Thresholds

The signal to noise ratio of the meter is above 80 db at full scale (1 part in 10,000). When the signal amplitude becomes so small that it is indistinguishable from noise, it is better to record 0 than a small random value. Snap Threshold registers (Advanced tab in Power Meter Viewer Utilities) tell the meter when to record 0 instead of the measurement result. The factory defaults for CT's are expressed in percentages, and have a default value of 0.04% full scale. The voltage thresholds are in absolute value, the recommended minimum voltage is 1.0 volt.

Multipliers

The meter has registers that allow potential transformers and series current transformers to be used with the VerifEye® meter. These registers allow for transformer winding ratios or other scaling adjustments included in the meter processing to eliminate post-process scaling. Adjustments to voltage are global to the meter, while CT's can be adjusted channel by channel. The multiplier is a floating-point number and can also be used for post installation calibration, if needed. The default value is 1.0.

CT Phase Shifts

Current transformers experience a small magnetizing current that is out of phase with the measurement current. Phase shift registers are available on a per channel basis, and allow corrections of +/- 3 degrees. The Power Meter Viewer Utilities software loads the default phase shift for the CT types available in the picker list. If no phase shift information is available, then enter the accuracy class in degrees (e.g., 1% = 1.0 degree).

Demand

VerifEye® meters use a 15 minute sliding window to keep track of electrical demand. The Peak Demand and Present Demand registers contain the highest average power consumption in any 15 minute interval and the average power consumption in the last 15 minute interval. Use the Clear Peak Demand register to reset the peak demand detector.

7 RTU PROGRAMMING AND SCRIPTING

This section is for the programmer of the RTU or host system, and describes meter and element addressing, register locations, data formats, and protocol examples.

7.1 Register Organization

The VerifEye® meter communicates through the reading and writing of registers. Registers are organized into functional groups, and are compliant with the SunSpec Modbus interface model.

- SunSpec Common Registers
- SunSpec TCP Network Stack Registers
- SunSpec Serial Interface Registers
- SunSpec Energy Meter

The complete register set is included as an Excel file on the supplied thumb drive, or go to <https://www.leviton.com>, and go to the S7000 product page's Support/Downloads section.

7.2 Element vs. System Scope

Element

Physically, the term Element describes groups of three channel sections identified by an alphabetic letter on the silk screen of the PCBA (A,B,C,D). In a three-phase power system, these channel sections correspond to electric circuits.

Logically, the term Element describes the scope of a data item, register or point (Modbus register or BACnet object). Each Element base point is accessed by choosing the appropriate Modbus address, BACnet object range, or BACnet structured view. Elements have points that refer to individual channels or to sums or averages of those channels. Registers that contain data in more than one channel, are identified as being sums or averages of the enabled channels within an Element. In a BACnet structured view, an Element represents a level of organization for related points.

Channel

Channels are identified on the circuit board as CH1, CH2, or CH3 and represent physical CT inputs. In three-phase system configurations, these correspond to a current load on a corresponding line voltage. In single-phase configurations, they are used to identify a CT location. Registers providing data for an individual channel are also described as elements in their scope as a unique value exists for each Slave Address or BACnet object instance.

System

The term "System" refers to registers defining the characteristics of the entire circuit board. System registers report the same value independent of the slave address. Under BACnet structured view the system points are grouped together.

7 RTU PROGRAMMING AND SCRIPTING

7.3 Configuring Element and Channel Register for Service Types

The Power Meter Viewer Utilities software enforces all element configurations to form a valid electrical system. Configurations performed by remote systems may produce unexpected results if configurations are internally inconsistent. The following tables document how to configure element and channel registers for each service type. Every register should be explicitly written.

RED text indicates Required Values.

PURPLE text indicates Suggested Defaults, if data is unknown.

Modbus Absolute Address/BACnet Object Assignments for Setting up Service Types

Register Template						
Service Type	2207					
V_Input	2217					
Description	2617					
Channels	Volt Ref	CT Type	Range	Phase Shift	CT Multiplier	CT Sign
CH1	2220	2223	2224,2225	2224,2225	2221,2222	2226
CH2	2229	2232	2227,2228	2233,2234	2230,2231	2235
CH3	2238	2241	2236,2237	2242,2243	2239,2240	2244

Configurations

4 Wire, 3 Phase (Wye)						
Service Type	1					
V_Input	1 or 2					
Description	31 Char					
Channels	Volt Ref	CT Type	Range	Phase Shift	CT Multiplier	CT Sign
CH1	L1 – N [1]	mV [1] or RoCoil [2]	Any > 0A	-3.0° to +3.0°	Any > 0 [1]	0 or 1
CH2	L2 – N [2]	mV [1] or RoCoil [2]	Any > 0A	-3.0° to +3.0°	Any > 0 [1]	0 or 1
CH3	L3 – N [3]	mV [1] or RoCoil [2]	Any > 0A	-3.0° to +3.0°	Any > 0 [1]	0 or 1

3 Wire, 3 Phase (Delta)						
Service Type	2					
V_Input	1 or 2					
Description	31 Char					
Channels	Volt Ref	CT Type	Range	Phase Shift	CT Multiplier	CT Sign
CH1	L1 – N [1]	mV [1] or RoCoil [2]	Any > 0A	-3.0° to +3.0°	Any > 0 [1]	0 or 1
CH2	L2 – N [2]	mV [1] or RoCoil [2]	Same as 1	Same as 1	Same as 1	0 or 1
CH3	L3 – N [3]	mV [1] or RoCoil [2]	Same as 1	Same as 1	Same as 1	0 or 1

Even though CH2 is calculated internally, it is recommended that the CT settings reflect those from CH1, rather than left at the factory default settings to facilitate configuration validation from the RTU.

7 RTU PROGRAMMING AND SCRIPTING

2 Wire, 1 Phase (Plug Load)						
Service Type	3					
V_Input	1 or 2					
Description	31 Char					
If any channel needs to be turned OFF, set the CT Type to OFF.						
Channels	Volt Ref	CT Type	Range	Phase Shift	CT Multiplier	CT Sign
CH1	ANY [1-6]	mV [1] or RoCoil [2]	Any > 0A	-3.0° to +3.0°	Any > 0 [1]	0 or 1
CH2	ANY [1-6]	mV [1] or RoCoil [2]	Any > 0A	-3.0° to +3.0°	Any > 0 [1]	0 or 1
CH3	ANY [1-6]	mV [1] or RoCoil [2]	Any > 0A	-3.0° to +3.0°	Any > 0 [1]	0 or 1

3 Wire, 1 Phase (Split Phase)						
Service Type	4					
V_Input	1 or 2					
Description	31 Char					
Even though CH3 is not used for computation, it is recommended that the CT settings reflect those from CH1 rather than left at the factory default settings to facilitate configuration validation from the RTU.						
Channels	Volt Ref	CT Type	Range	Phase Shift	CT Multiplier	CT Sign
CH1	L1 – N [1]	mV [1] or RoCoil [2]	Any > 0A	-3.0° to +3.0°	Any > 0 [1]	0 or 1
CH2	L2 – N [2]	mV [1] or RoCoil [2]	Any > 0A	-3.0° to +3.0°	Any > 0 [1]	0 or 1
CH3	L3 – N [3]	OFF [0]	Any > 0A	-3.0° to +3.0°	Any > 0 [1]	0 or 1

Disabled (OFF)						
Service Type	5					
V_Input	1 or 2					
Description	31 Char					
Even though disabled channels are not used in calculations and report 0.0, they still contain configuration information. It is suggested that they be set to a known value, rather than left at their factory default settings to facilitate configuration validation by the RTU.						
Channels	Volt Ref	CT Type	Range	Phase Shift	CT Multiplier	CT Sign
CH1	L1 – N [1]	OFF [0]	Any > 0A	-3.0° to +3.0°	Any > 0 [1]	0 or 1
CH2	L2 – N [2]	OFF [0]	Any > 0A	-3.0° to +3.0°	Any > 0 [1]	0 or 1
CH3	L3 – N [3]	OFF [0]	Any > 0A	-3.0° to +3.0°	Any > 0 [1]	0 or 1

7 RTU PROGRAMMING AND SCRIPTING

7.4 Configuring System Registers

Modbus Absolute Address/ BACnet Object Assignment		Configurations	
Register Template		System	
Description	2601	Description	31 Char
PF Sign Convention	2248	PF Sign Convention	ANSI [1] or IEEE[2]
V1 Multiplier	2203,2204	V1 Multiplier	Any > 0 [1]
V2 Multiplier	2205,2206	V2 Multiplier	Any > 0 [1]

7.5 Modbus Protocol Commands

If configured for Modbus, the networked power meter family follows the Modbus RTU protocol and supports the following command set.

Supported Modbus Commands		
Command Name	Command Number (Hex)	Description
Read Holding Registers	03	Used to read the data values from the VeriEye® meter
Write Single Register	06	Used to write a single holding register to a VeriEye® meter
Report Slave ID	11	Used to read information from the identified VeriEye® meter

Slave Address

For Modbus/TCP, the base slave address (or unit address, as the Modbus TCP spec calls it), is fixed at 1.

Refer to the section **Serial Protocols** for additional information on setting the Slave Address and finding the address of a specific meter element.

Modbus String Entry

Registers that are identified as **strings** are handled uniquely by the VeriEye® power meter. Each register in the string block must be written sequentially without interruption either by using a **write multiple** command, or by sending single register commands back to back. The final character in the string **MUST** be a NULL character (ASCII 0). The meter processes the entire string only if these two conditions are met, otherwise, the data is ignored. This special processing has been implemented to protect partial updates for network settings.

7 RTU PROGRAMMING AND SCRIPTING

String example 1: Change a Static IP Address

Change the IP address of a meter from 192.168.2.8 to 192.168.2.9.

Note: Update the entire IP address, not just the “8” to “9.”

Internally, the meter uses a single string buffer for all string register operations and unspecified entries continue to contain the previous buffer contents unless specifically written. Write every register from the beginning of the block to the end.

Reg (dec)	1079	1080	1081	1082	1083	1084	1085	1086
Reg (hex)	04 37	04 38	04 39	04 3A	04 3B	04 3C	04 3D	04 3E
Value (Chr)	'1' '9'	'2' ' '	'1' '6'	'8' ' '	'9' NUL	NUL NUL	NUL NUL	NUL NUL
Value (hex)	31 39	32 28	31 36	38 2E	32 2E	39 00	00 00	00 00
	START							STOP

Specific Implementation Examples – Element A Set to ID 1

Note that in Modbus, the CRC communicated is LSB then MSB.

VIA MODBUS RTU (SERIAL), USING FUNCTION
CODE 6/WRITE SINGLE REGISTER.

ID	FC	ADDR		DATA		CRC	
01	06	04	37	31	39	EC	B6
01	06	04	38	32	2E	9C	4B
01	06	04	39	31	36	CD	71
01	06	04	3A	38	2E	3B	2B
01	06	04	3B	32	2E	6C	4B
01	06	04	3C	39	00	5A	A6
01	06	04	3D	00	00	19	36
01	06	04	3E	00	00	E9	36

VIA MODBUS RTU (SERIAL), USING FUNCTION
CODE 16/WRITE MULTIPLE REGISTER.

ID	FC	ADDR		#REGS	LN	DATA0		DATA1		DATA2		DATA3		DATA4	
01	10	04	37	00 08	10	31	39	32	2E	31	36	38	2E	32	2E
DATA5		DATA6		DATA7		CRC									
39	00	00	00	00	00	9B	99								

7 RTU PROGRAMMING AND SCRIPTING

VIA MODBUS TCP (ETHERNET), USING FUNCTION CODE 6/WRITE SINGLE REGISTER.

TXNID	PROID	LENGT		ID	FC	ADDR		DATA (TXNID will be arbitrary)			
01	87	00	00	00	06	01	06	04	37	31	39
01	88	00	00	00	06	01	06	04	38	32	2E
01	89	00	00	00	06	01	06	04	39	31	36
01	8A	00	00	00	06	01	06	04	3A	38	2E
01	8B	00	00	00	06	01	06	04	3B	32	2E
01	8C	00	00	00	06	01	06	04	3C	39	00
01	8D	00	00	00	06	01	06	04	3D	00	00
01	8E	00	00	00	06	01	06	04	3E	00	00

VIA MODBUS TCP (ETHERNET), USING FUNCTION CODE 16/WRITE MULTIPLE REGISTER.

TXNID	PROID	LENGT		ID	FC	ADDR	#REGS	LN	DATA0	DATA1						
01	87	00	00	00	17	01	10	04	37	00	08	10	31	39	32	2E

DATA2	DATA3	DATA4	DATA5	DATA6	DATA7					
31	36	38	2E	32	2E	39	00	00	00	00

String example 2: Element Description

Change the Element Description from "Mains Bld 100" to "Mains Bld 101".

Note: Update the entire IP Address, not just the "0" to "1."

Internally, the meter uses a single string buffer for all string register blocks and unspecified entries continue to contain the previous buffer contents unless specifically written.

Reg (dec)	2617	2618	2619	2620	2621	2622	2623	2624
Reg (hex)	0A 39	0A 3A	0A 3B	0A 3C	0A 3D	0A 3E	0A 3F	0A 40
Value (Chr)	'M' 'a'	'i' 'n'	's' ''	'B' 'l'	'd' ''	'1' '0'	'1' Nul	NulNul
Value (hex)	4D 61	69 6E	73 20	62 6C	64 20	31 30	31 20	00 00
	START							STOP

Reg (dec)	2625	2626	2627	2628	2629	2630	2631	2632
Reg (hex)	0A 41	0A 42	0A 43	0A 44	0A 45	0A 46	0A 47	0A 48
Value (Chr)	NulNul	NulNul	NulNul	NulNul	NulNul	NulNul	NulNul	NulNul
Value (hex)	00 00	00 00	00 00	00 00	00 00	00 00	00 00	00 00
	START							STOP

7 RTU PROGRAMMING AND SCRIPTING

Specific Implementation Examples – Element A Set to ID 1

VIA MODBUS RTU (SERIAL), USING FUNCTION
CODE 6/WRITE SINGLE REGISTER

ID	FC	ADDR		DATA		CRC	
01	06	0A	39	4D	61	AE	A7
01	06	0A	3A	69	6E	05	A3
01	06	0A	3B	73	20	DF	37
01	06	0A	3C	62	6C	63	53
01	06	0A	3D	64	20	30	C6
01	06	0A	3E	31	30	FE	5A
01	06	0A	3F	31	20	AE	56
01	06	0A	40	00	00	8B	C6
01	06	0A	41	00	00	DA	06
01	06	0A	42	00	00	2A	06
01	06	0A	43	00	00	7B	06
01	06	0A	44	00	00	CA	07
01	06	0A	45	00	00	9B	C7
01	06	0A	46	00	00	6B	C7
01	06	0A	47	00	00	3A	07
01	06	0A	48	00	00	0A	04

VIA MODBUS RTU (SERIAL), USING FUNCTION
CODE 16 / WRITE MULTIPLE REGISTER

ID	FC	ADDR		#REGS	LN	DAT00		DAT01		DATA02		DAT03		DATA04			
01	10	0A	39	00	10	20	4D	61	69	6E	73	20	62	6C	64	20	
DAT05		DAT06		DAT07		DAT08		DAT09		DAT10		DAT11		DAT12		DAT13	
31	30	31	20	00	00	00	00	00	00	00	00	00	00	00	00	00	00
DAT14		DAT15		CRC													
00	00	00	00	3A	18												

7 RTU PROGRAMMING AND SCRIPTING

VIA MODBUS TCP (ETHERNET), USING FUNCTION
CODE 6/WRITE SINGLE REGISTER

TXNID	PROID		LENGT		ID	FC	ADDR		DATA (TXNID will be arbitrary)		
01	87	00	00	00	06	01	06	0A	39	4D	61
01	88	00	00	00	06	01	06	0A	3A	69	6E
01	89	00	00	00	06	01	06	0A	3B	73	20
01	8A	00	00	00	06	01	06	0A	3C	62	6C
01	8B	00	00	00	06	01	06	0A	3D	64	20
01	8C	00	00	00	06	01	06	0A	3E	31	30
01	8D	00	00	00	06	01	06	0A	3F	31	20
01	8E	00	00	00	06	01	06	0A	40	00	00
01	8F	00	00	00	06	01	06	0A	41	00	00
01	90	00	00	00	06	01	06	0A	42	00	00
01	91	00	00	00	06	01	06	0A	43	00	00
01	92	00	00	00	06	01	06	0A	44	00	00
01	93	00	00	00	06	01	06	0A	45	00	00
01	94	00	00	00	06	01	06	0A	46	00	00
01	95	00	00	00	06	01	06	0A	47	00	00
01	96	00	00	00	06	01	06	0A	48	00	00

VIA MODBUS TCP (ETHERNET), USING FUNCTION
CODE 16/WRITE MULTIPLE REGISTER

TXNID	PROID		LENGT		ID	FC	ADDR		#REGS	LN	DAT00		DAT01			
01	87	00	00	00	27	01	10	04	37	00	10	20	4D	61	69	6E
DAT02	DAT03	DAT04		DAT05		DAT06		DAT07		DAT08		DAT09				
73	20	62	6C	64	20	31	30	31	20	00	00	00	00			
DAT10	DAT11	DAT12		DAT13		DAT14		DAT15								
00	00	00	00	00	00	00	00	00	00							

7 RTU PROGRAMMING AND SCRIPTING

7.6 Floating Point Registry Entry

The VerifEye® meter uses 32-bit IEEE 754 formatted floating point numbers for reporting results and storing scalable user register values, such as CT range and CT and PT scaling factors. As these registers require two 16-bit Modbus addresses to convey values, these registers must be accessed as multiple registers or accessed sequentially without interruption.

Note: The reason for preventing floating point registers from being updated as single 16-bit registers is that interim values (when the number is half entered) represent valid but unknown numeric values. Requiring both the MSW and LSW registers to be written sequentially prevents meter data from having unknown and potentially very large scaling factors applied to measurement data between register writes.

Selecting the Data Type

Note: The RTU program has built-in support for multiple data types including floating point. The VerifEye® meter data is stored as MSW, LSW, which may take some trial and error to identify in the RTU setup. Float ABCD is an example of the how this RTU identifies the matching byte order.

It is anticipated that command-line programmers or script writers may prefer to enter data in hexadecimal format. Non-programmers using Modbus or BACnet utilities (or those using ViewPoint HD) may prefer to use decimal notation. This example works through the details of converting information found in our user documentation (decimal) into a hexadecimal format which should cover the highest level of complexity.

Entering Floating Point Data Using a Script

Consider the process of setting the CH1 CT Full Scale Rating to a value of 100.00 amps for a meter having an element at slave address #1.

1. Convert 100.00 into an IEEE 754 floating point format by entering the number in a conversion utility, such as an Internet utility or ViewPoint HD.

- a) Internet Utility - The 16-bit floating point representation of 100.00 is shown below as 0x42C8 0x0000. These are the required MSW and LSW register contents.

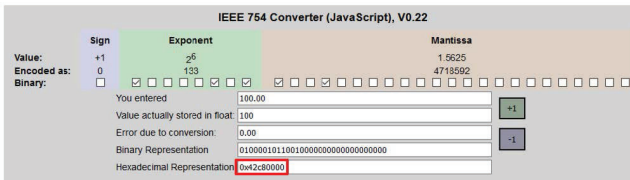
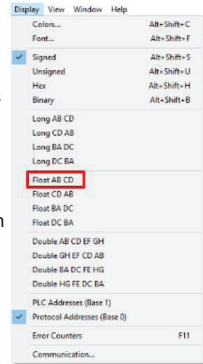

7 RTU PROGRAMMING AND SCRIPTING

b) Leviton Power Meter Viewer

- c) If an Internet utility is not available, Leviton Power Meter Viewer has a built-in conversion utility under the Advanced Tab. Enter **100.00** and press **Convert to Modbus Integers** button.

Floating Point (IEEE 754) to Modbus Integer Converter

Floating Point Number		MSW	LSW
100	Convert to Modbus Integers	17096	0
MSW	LSW	Floating Point #	
17096	0	100	

This utility identifies that the MSW and LSW registers must be set to 17096 and 0 (decimal). If hexadecimal notation is required, these decimal values can be converted using a utility, such as the MS Windows Calculator (under Programmer mode), as shown below.

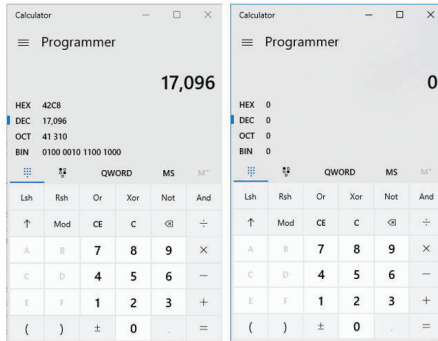

After converting, 0x42C8 0x0000 is the MSW and LSW register value.

- Identify which configuration registers control of the CH1 CT Full Scale Rating. Either refer to the MS Excel Register List (USB drive) or use the Power Meter Viewer Utilities software to discover the address of the displayed data.
 - Open the MS Excel Register List and locate the CH1 CT Full Scale Rating Registers under the USER CONFIG POINTS group.

Modbus Register Name	Modbus Register	Absolute Address
CH1 CT Full Scale Rating (MSW)	2218	42219
CH1 CT Full Scale Rating (LSW)	2219	42220

7 RTU PROGRAMMING AND SCRIPTING

- b) Connect to the 7000 Series meter using the Leviton Power Meter Viewer. Navigate to the Meter Setup tab and press the ? icon. Hover over the Element A setup portion of the window. This launches the data exploring tool and indicates the addresses of the registers controlled or displayed by this window.

Context Help

A

DEFINITIONS:
 CT Configuration for Element.
 Use Copy button to copy settings to other element(s).
 Element Description: Description for this Element
 V-Input: Select V-Input source (1/2)
 Service: Select the service type
 CT Enable: Only available in 2-wire 1-phase to enable or disable the CT. Disabling CT sets the CT Type to OFF
 Volt Reference: Line to Neutral or Line to Line. Choices available depend on the service type selected
 Type/CT Picker: A CT Picker list is available to choose the CT Type
 Range: CT Picker populates this value for the selected CT
 Phase Shift: CT Picker populates this value for the selected CT
 Multiplier: CT Picker populates this value for the selected CT
 CT Sign: Use this button if the wiring of CT is reversed

ModBus Address (16 bit) MSW, LSW BACNet Object
Note: Add Multiple of 1000 for BACnet object address for Elements B and greater.

REGISTER / OBJECT ADDRESSES	Element	CH1	CH2	C-H3
Description	MSW, LSW	MSW, LSW	MSW, LSW	MSW, LSW
Element Description	2617-2632			
V-Input	2217			
Service Type	2207			
CT Enable	-----			
Volt Reference		2220	2229	2238
CT Type		2223	2232	2241
Range		2218, 2219	2227, 2228	2236, 2237
Phase Shift		2224, 2225	2233, 2234	2242, 2243
Range		2221, 2222	2230, 2231	2239, 2240

The desired control registers are 2218 (MSW) and 2219 (LSW).

Convert the register addresses of interest into hexadecimal notation (if required).

Calculator - Programmer

2,218

HEX 8AA
 DEC 2,218
 OCT 4,252
 BIN 1000 1010 1010

Calculator - Programmer

2,219

HEX 8AB
 DEC 2,219
 OCT 4,253
 BIN 1000 1010 1011

3. Calculate the CRC-16 (Modbus RTU) for the expression. There are several variations of the CRC-16. Ensure the one you are using is for Modbus. The CRC is entered LSB first.

Enter the Entire Expression into a CRC Calculator (a web utility can be helpful).

Input Data

01 06 08 AA 42C8

CRC-16 (Modbus)

0xBC9A

7 RTU PROGRAMMING AND SCRIPTING

4. Put it all together.

VIA MODBUS RTU (SERIAL), USING FUNCTION
CODE 6/WRITE SINGLE REGISTER

ID	FC	ADDR		DATA		CRC (note to CRC order is swapped)	
01	06	08	AA	42	C8	98	BC
01	06	08	AB	00	00	FA	4A

VIA MODBUS RTU (SERIAL), USING FUNCTION
CODE 16 WRITE MULTIPLE REGISTER

ID	FC	ADDR		REGS	LN	DATA0	DATA	CRC
01	06	08	AA	00 02	04	42 C8	00 00	8B EE

VIA MODBUS TCP (ETHERNET), USING FUNCTION
CODE 6/WRITE SINGLE REGISTER

TXNID	PROID	LENGT		ID	FC	ADDR	DATA (TXNID will be arbitrary)	
01	87	00	00	00 06	01	06 08	AA	42 C8
01	88	00	00	00 06	01	06 08	AB	00 00

VIA MODBUS TCP (ETHERNET), USING FUNCTION
CODE 16/WRITE MULTIPLE REGISTER

TXNID	PROID	LENGT		ID	FC	ADDR	#REGS	LN	DATA0	DATA1
01	87	00	00	00 0B	01	10 08	AA	00 02	04 42 C8	00 00

Commands Requiring a Processor Reset

Register manipulation of communication protocols or addressing requires that the VerifEye® meter perform a soft reset. Register 2100 can receive a user command to facilitate this process. BACnet users write a [1] and Modbus users write [1234] to perform a soft reset. The meter reboot time is approximately 10 seconds.

See the Modbus examples on the Leviton Manufacturing web site or included with your electronic documentation for additional support on programming Modbus.

7 RTU PROGRAMMING AND SCRIPTING

7.7 BACnet

Building Automation and Control Network (BACnet) protocol was developed under the auspices of the American Society of Heating, Refrigerating and Air-Conditioning Engineers (ASHRAE) and is recognized as an American National, European, and ISO global standard.

BACnet Device ID: All device IDs on a BACnet network must be unique. Refer to the section Serial Protocols and refer to the Register List for additional information.

Serial: The serial version supports writable max_master, MS/TP address, max_info_frames properties in the device object for MS/TP networks. For best network performance, the max_master should be set to the highest MS/TP MAC address on the network. The MS/TP address (object 1069) must be unique on the MS/TP network. The max_info_frames does not need to be changed in most installations.

Ethernet: Ethernet versions can register as Foreign Devices to a BBMD. BBMD stand for BACnet/IP Broadcast Management Device. The BBMD IP address can be set from Power Meter Viewer Utilities or through character string object 2264. A value of 0.0.0.0 disables foreign device registration. This process requires a processor soft reset.

BACnet Structured View

The VerifEye® meter supports the Structured View (SV) object container. If this option is supported in the BACnet exploring tool, objects will be grouped logically into elements which can be named to reflect electrical or physical locations, followed by system objects, as shown below.

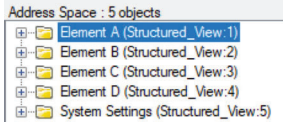

7 RTU PROGRAMMING AND SCRIPTING

Within each element, Structured View lists the BACnet objects by Object Type and then by numeric number as shown below. In addition objects for elements are grouped in a “hotel room” scheme. That is Element A (and system objects) have a range from 0-9999, Element B 10000-19999, Element C 20000-29999, to Element P on the VerifEye® 48 circuit meter 150000-159999. Some BACnet explorer tools have additional sorting capabilities.

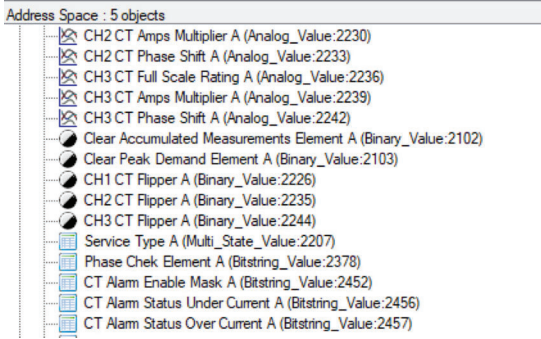

Supported BACnet Object Types		
Object Type	Abbreviation	Typical Usage
Analog Input:	AI	Meter Readings (floating point numeric inputs)
Analog Value:	AV	Analog User Settings (floating point numeric outputs)
Binary Value:	BV	User Boolean Settings
Multi State Value:	MSV	Enumerated Settings
BitString Value:	BSV	Bitfield Status Words and Settings
Positive Integer Value:	PIV	Restricted Range User Settings
Character String Value:	CSV	User Text string settings

8 APPENDIX A: LCD MENU NAVIGATION

About Meter

The complete LCD navigation map is shown in diagram form in the next few pages. The "About Meter" menu is the most commonly accessed item which requires 5 down presses or 1 up (rolling menu) to access.

Main Menu

View Communications
Real Time Values
View Meter Setup
Verify Installation
Log In/Out
About Meter

The **About Meter** menu contains the following items which are displayed 4 lines at a time and accessed by using the up and down keys on the front display.

S7000 v2.00	Model and version
Serial: P121501001	Serial number
LAN: Connected	State of LAN connection
IP: 10.1.1.1	Current IP address
MC 00:0D:63:00:00:00	MAC Address
Line Frequency: 60.0	Current line frequency
Obvius	Manufacturer name
Copyright (c) 2018	Copyright notice
Protocol: Modbus	Communication protocol
Modbus Address: 1	Modbus address
Modbus Port: 502	Modbus port
MSTP Address: 1	MSTP address
Baud Rate: 9600	RS485 baud rate
DHCP: ON	Current DHCP Setting
BACnet Port: 47808	BACnet Port
BACnet DevID: 527000	BACnet Device ID
Pulse In 1: 0.0	Channel 1 pulse accumulator
Pulse In 2: 0.0	Channel 2 pulse accumulator
System Descriptor: 70x48	System description set by user
UTC Date / Time: 2018-04-24 10:04:08	Current time in UTC (GMT)

8 APPENDIX A: LCD MENU NAVIGATION

Menu Navigation

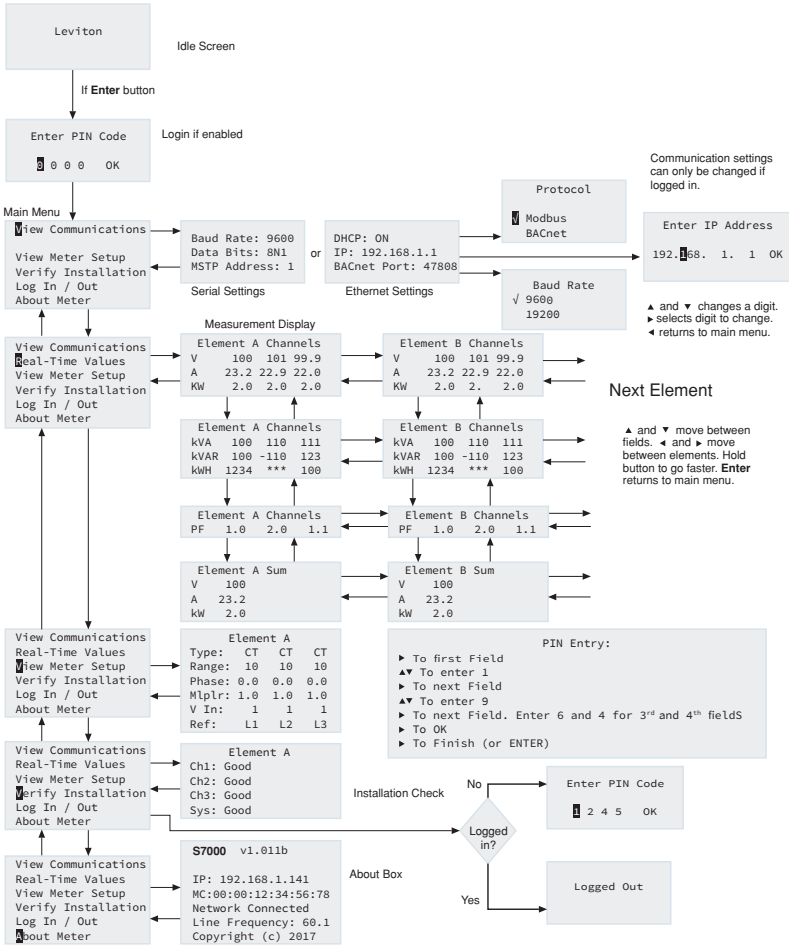

8 APPENDIX A: LCD MENU NAVIGATION

Communication Navigation

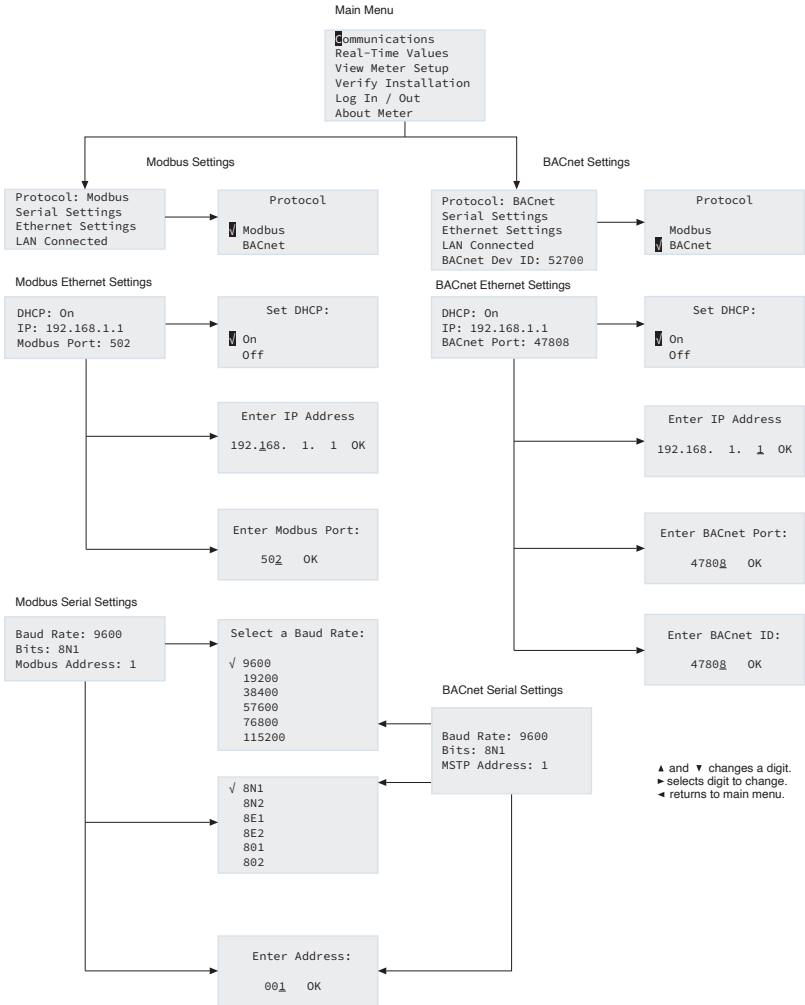

9 APPENDIX B: TECHNICAL SPECIFICATIONS

Main Specifications

Specification	Description
Service Types	Single phase, split phase, three phase-four wire (WYE), three phase-three wire (Delta)
Voltage Input Channels	90-346 VAC line-to-neutral, 600V line-to-line, CAT III, For 48 Circuit Models Only: two independent voltage reference inputs.
Current Channels	3, 12, 24, or 48 channels, 0.525 VAC max, 333 mV CTs, 0-4,000 Amps depending on current transducer.
Maximum Current Input	150% of current transducer rating (mV CTs) to maintain accuracy. Measure up to 4000A with R6Coil CTs.
Measurement Type	True RMS using high-speed digital signal processing (DSP) with continuous sampling.
Line Frequency	50-60 Hz (45 – 70 Hz measureable range) – measurement taken L1-N
Power	From L1 Phase to L2 Phase. 90-600VAC RMS CAT III 50/60Hz, 500mA AC Max Use of 12 volt auxiliary output requires 100 VAC minimum input voltage.
AC Protection	0.5A Fuse 200kA interrupt capacity
Power Out	Unregulated 12VDC output, 200 mA, self-resetting fuse
Waveform Sampling	1.8 kHz
Parameter Update Rate	1 second
Measurements	Volts, Amps, kW, kVAR, kVA, aPF, dPF, kW demand, kVA demand, Import (Received) kWh, Export (Delivered) kWh, Net kWh, Import (Received) kVAh, Export (Delivered) kVAh, Net kVAh, Import (Received) kVARh, Export (Delivered) kVARh, Net kVARh, THD, Theta, Frequency. All parameters for each phase and system total.
Accuracy	0.2% ANSI C12.20-2010 Class 0.2
Resolution	Values reported in IEEE-754 single precision floating point format (32 bit).
Indicators	4-line display, tri-color backlight (PhaseChek™)
Pulse Inputs	VerifEye® 70D12, 71D12 – 4 inputs VerifEye® 70D24, 70D48, 71D24, 71D48 – 2 inputs 3.3V sourcing voltage (current limited) to customer dry contact pulse output Maximum Pulse Rate 10 HZ (50 msec minimum transition time)
Alarm Output	Over/Under Voltage & Current (SPDT Relay - 30 VDC)

9 APPENDIX B: TECHNICAL SPECIFICATIONS

Communication Specifications

Specification	Description
Hardware	RS-485, Ethernet, & USB (for configuration only)
Supported Protocols	Modbus RTU or BACnet Master Slave Token Passing protocol (MS/TP) Modbus (using SunSpec IEEE-754 single precision floating point model) Modbus TCP BACnet IP
Max Communication Length (RS485)	1200 meters total length, with Data Range of 100K bits/second or less
RS-485 Loading	1/8 unit
Communication Rate (baud)	Modbus: 9600 (Default), 19200, 38400, 57600, 76800, 115200 BACnet: 9600 (Default), 19200, 38400, 76800
Data Bits	8
Parity	None, Even, Odd
Stop Bit	2, 1
Termination	None provided

Mechanical Specifications

Specification	Description
Wire Connections & Voltage	12-22 AWG 600 VAC, Voltage connection must be #14 AWG or larger & 600 VAC rated
Mounting	Enclosure or Panel Mount
High Voltage Cover	IP30 (embedded version)
Operating Temperature	-20 to +60°C (-4 to 140°F) (the colder the temperature the more voltage needed to power the board)
Humidity	5% to 95% non-condensing
Enclosure	ABS Plastic, 94-V0 flammability rating, connections sized for 1-inch EMT conduit
Dimensions	(L) 24.8cm x (W) 25.1cm x (H) 8.0 cm (9.8" x 9.8" x 3.1") (12 enclosure version) (L) 17.8cm x (W) 26.3cm x (H) 8.0 cm (7.0" x 10.4" x 3.1") (12 mounting plate version) (L) 33.7cm x (W) 25.1cm x (H) 8.0 cm (13.3" x 9.8" x 3.1") (48 enclosure version) (L) 26.2cm x (W) 24.1cm x (H) 8.0 cm (10.3" x 9.5" x 3.1") (48 mounting plate version)
PCBA Dimensions	(L) 21.6cm x (W) 21.6cm x (H) 6.4 cm (8.5" x 8.5" x 2.5")

Power Meter Viewer Utilities Minimum System Requirements

Specification	Description
Operating System	Windows® 11
Communications Port	USB or Ethernet connectivity

10 STANDARD STATEMENTS AND WARRANTY

FCC STATEMENT:

This equipment has been tested and found to comply with the limits for a Class A digital device, pursuant to Part 15 of the FCC Rules. These limits are designed to provide reasonable protection against harmful interference when the equipment is operated in a commercial environment. This equipment generates, uses, and can radiate radio frequency energy and, if not installed and used in accordance with the instruction manual, may cause harmful interference to radio communications. Operation of this equipment in a residential area is likely to cause harmful interference in which case the user will be required to correct the interference at his own expense.

FCC SUPPLIER'S DECLARATION OF CONFORMITY:

Models 71D03, 71D12, 71D24, 71D48, 70D03, 70D12, 70D24, and 70D48 are sold by Leviton Manufacturing Inc. 201 N Service Rd, Melville, NY 11747. This device complies with Part 15 of the FCC Rules. Operation is subject to the following two conditions: (1) This device may not cause harmful interference, and (2) this device must accept any interference received, including interference that may cause undesired operation.

Any changes or modifications not expressly approved by Leviton Manufacturing Co., could void the user's authority to operate the equipment.

IC STATEMENT:

This device contains license-exempt transmitter(s)/receiver(s) that comply with Innovation, Science and Economic Development Canada's license-exempt RSS(s). Operation is subject to the following two conditions:

- (1) This device may not cause interference.
- (2) This device must accept any interference, including interference that may cause undesired operation of the device.

TRADEMARK DISCLAIMER:

Leviton and the Leviton logo are the registered trademarks of Leviton Manufacturing Co., Inc. VeriEye is a Leviton trademark registered in the U.S., Canada, and Mexico. Use herein of third party trademarks, service marks, trade names, brand names and/or product names are for informational purposes only, are/may be the trademarks of their respective owners; such use is not meant to imply affiliation, sponsorship, or endorsement. PhaseChek and TouchSaf are trademarks of DENT Instruments. Modbus is a trademark of Schneider Electric USA, Inc. and BACnet is a trademark of ASHRAE.

Leviton Manufacturing Co., Inc.

201 North Service Road, Melville, NY 11747

Telephone : 1-800-824-3005

Visit Leviton's Web site at <http://www.leviton.com>.

© 2025 Leviton Manufacturing Co., Inc. All rights reserved.

Specifications and price are subject to change at any time without notice.

FOR CANADA ONLY.

For warranty information and/or product returns, residents of Canada should contact Leviton in writing at **Leviton Manufacturing of Canada ULC** to the attention of the **Quality Assurance Department, 165 Hymus Blvd, Pointe-Claire (Quebec), Canada H9R 1E9** or by telephone at **1 800 405-5320**.

LIMITED 5 YEAR WARRANTY

For Leviton's limited 5 year product warranty, go to www.leviton.com. For a printed copy of the warranty, call 1-800-824-3005.

For Technical Assistance Call: 1-800-824-3005 (USA Only) or 1 800 405-5320 (Canada Only)
www.leviton.com



WEB VERSION