

Advanced Multi-Circuit Meter Quick Start Guide



VerifEye®

Cat. Nos. 71D12, 71D24, 71D48, 70D12, 70D24, 70D48, 71C12, 71C24, and 71C48

WARNINGS:

- **HAZARD OF ELECTROCUTION, SHOCK, EXPLOSION, OR ARC FLASH. CAREFULLY READ AND FOLLOW INSTRUCTIONS:**
- **TO AVOID FIRE, SHOCK OR DEATH,** turn OFF all power supplying equipment before working on or inside the equipment. Use a properly rated voltage sensing device to confirm power is OFF.
- Follow safe electrical work practices. See NFPA 70E in the USA, or applicable local codes.
- This equipment **MUST** be installed and serviced by an electrician or other qualified personnel with the requisite knowledge, training and experience related to the installation and operation of this equipment.
- Product may use multiple voltage/power sources. Be sure all sources of power have been disconnected before servicing.
- Do not depend on this product for voltage indication.
- Only install this product on insulated conductors.
- If the meter appears damaged or defective, first disconnect all power to the meter, and then call or e-mail Technical Support for assistance.
- **DO NOT EXCEED 346V Line to Neutral or 600V Line to Line (L-L).** This meter is equipped to monitor loads up to 346V Line to Neutral (L-N). Exceeding this voltage will cause damage to the meter and danger to the user. Always use a Potential Transformer (PT) for voltages in excess of 346V L-N or 600V L-L. VerifEye-branded meters are 600 Volt Over Voltage Category III devices.
- For use in a Pollution Degree 2 or better environment only. A Pollution Degree 2 environment must control conductive pollution and the possibility of condensation or high humidity. Consider the enclosure, the correct use of ventilation, thermal properties of the equipment, and the relationship with the environment. Installation category: CAT II or CAT III.

WARNINGS:

- Provide a disconnect device to disconnect the meter from the supply source. Place this device in close proximity to the equipment, and within easy reach of the operator, and mark it as the disconnecting device. The disconnecting device shall meet the relevant requirements of IEC 60947-1 and IEC 60947-3 and shall be suitable for the application. In the US and Canada, disconnecting fuse holders can be used. Provide overcurrent protection and disconnecting device for supply conductors with approved current limiting devices suitable for protecting the wiring. If the equipment is used in a manner not specified by the manufacturer, the protection provided by the device may be impaired.
- For the complete safety information for this product, see the full user guide at www.leviton.com

CAUTIONS:

- This product is not intended for life or safety applications.
- Do not install this product in hazardous or classified locations.
- The installer is responsible for compliance with all applicable codes.
- Mount this product inside a suitable fire-proof and electrical enclosure.
- If the collector is connected directly to a source of voltage, the pulse isolator immediately burns out and becomes non-responsive.

SCAN TO LEARN MORE



PK-A3260-10-00-0E

ENGLISH

INSTALLATION INSTRUCTIONS

1. Remove covers.

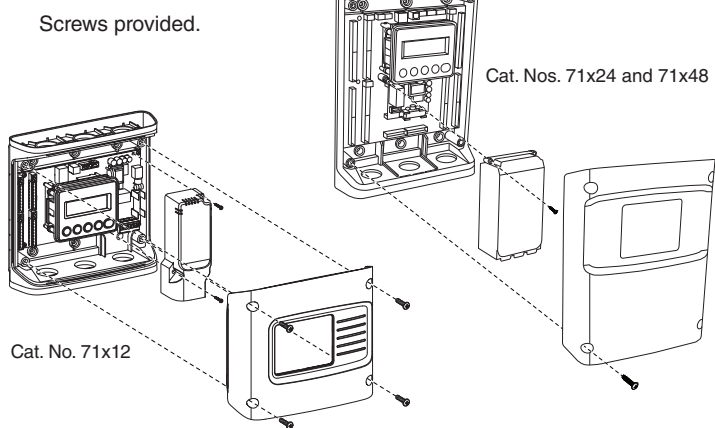

2. Mount.

Use the enclosure as a template, and tighten the screws to mount the meter.

NOTE: If meter is not available to use as a template, see the mechanical specifications drawing in the on-line user's guide at www.leviton.com

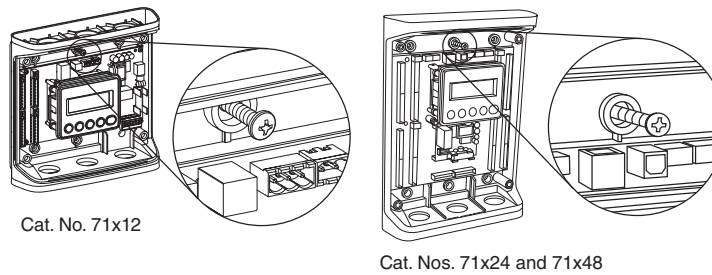

3. Connect.

- Conduit fittings
- Conduits
- Blanking plugs

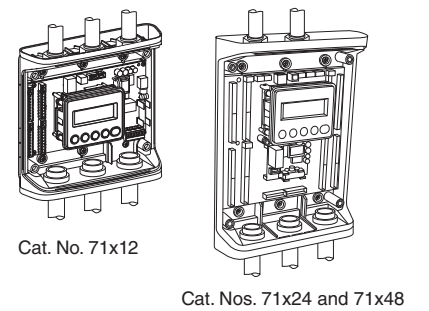

4. Connect voltage leads.

WARNING: RISK OF ELECTRIC SHOCK, EXPLOSION, OR ARC FLASH. DO NOT ENERGIZE METER WITH VOLTAGE COVER REMOVED. CAREFULLY READ AND FOLLOW INSTRUCTIONS.

Connect the voltage leads (L1, L2, L3 and N, as needed) to the meter through a dedicated disconnect or circuit breaker.

NOTE: Verify the circuit breaker is marked as the disconnect breaker for the meter.

Wiring the Meter in a Single-Phase Application: The meter is powered through the voltage between L1 and L2. For single-phase installations in which no L2 exists, install a jumper from N to L2. This connection provides power to the meter, maintaining L1-N as the metering voltage reference.

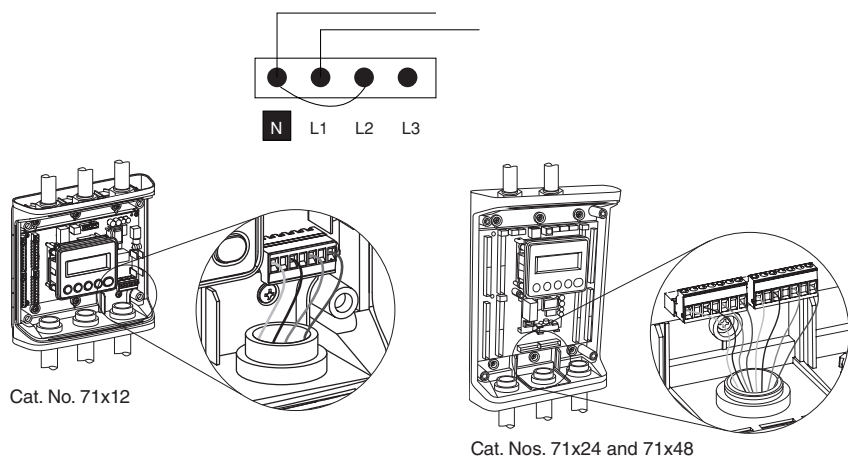

5. Attach high-voltage cover.

IP30 TouchSaf™ (with internal cover installed).

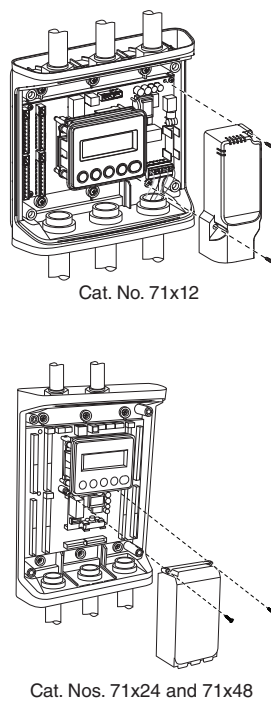

6. Connect CT and communications wiring.

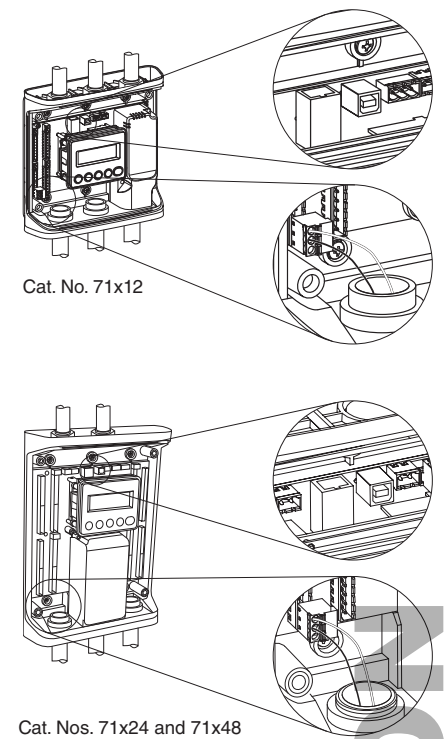

Communication Verification

Use the LCD's user interface to quickly confirm the settings required for each combination of interface and protocol. The interface is intuitive and groups together commonly associated registers. Arrows indicate how to move from one menu to the next. The active menu item is indicated by a blinking character on the LCD. Press ENTER to select a menu item, and press the up and down buttons to select the values supported by the meter.

NOTES:

- Verification includes confirmation of both the physical interface settings (serial or Ethernet) and the protocol (Modbus™ or BACnet™) settings.
- Changes to the meter configuration are limited to the communication interface using the LCD. If additional changes, such as CT type are required, use a software interface.

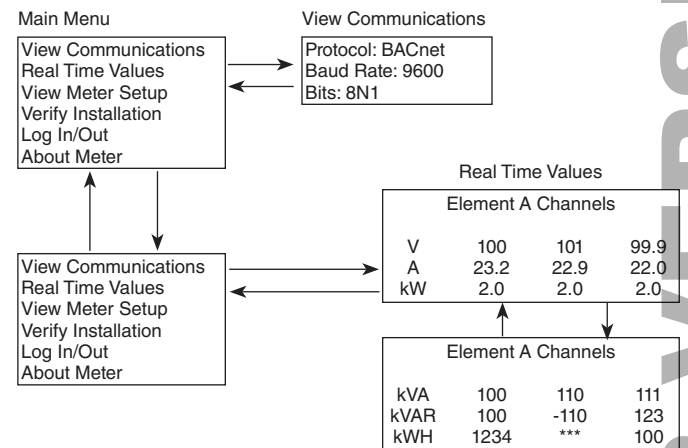

NOTE: A full navigational map is available in the Appendix of the user's guide on-line at www.leviton.com.

VerifEye S7 Configuration Utilities/Web Application

If your VerifEye model does not include the LCD user interface or if you prefer to verify the installation using software, use the VerifEye S7 Configuration Utilities PC application or the Web App. For an overview of VerifEye S7 Configuration Utilities or VerifEye Web App, refer to the section on configuration details in the user's guide on-line at www.leviton.com.

Pulse Inputs

Series 7000/7100 meters are equipped with pulse inputs (models 70D12, 71D12 - 4 inputs; models 70D24, 70D48, 71C24, 71D24, and 71D48 - 2 inputs). Pulse counting supports accumulation of consumption data from any external meter using a dry contact (Form A Relay) or open collector outputs. The pulse inputs are compatible with "low speed" meters. The pulse duration must exceed 50 mS in both the logic low- and high-state, which allows for a maximum input frequency of 10 Hz.

Pulse scaling, resetting, and accumulated values are accessed through registers and are "system" in scope. Refer to the register list, S7 Configuration Utilities or the user's guide for more information.

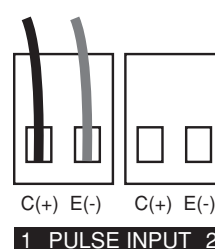

WEB VERSION

Wiring

1. Wire.

WARNINGS:

- **TO AVOID FIRE, SHOCK, OR DEATH; TURN OFF POWER** at circuit breaker or fuse and test that power is OFF before wiring!
- **HIGH-VOLTAGE MAY BE PRESENT.** To be installed by an electrician or other qualified personnel only.

a. Wiring in a 3-wire, split-phase service panel.

Configurations shown, are for service types available in the **METER SETUP** drop-down menu.

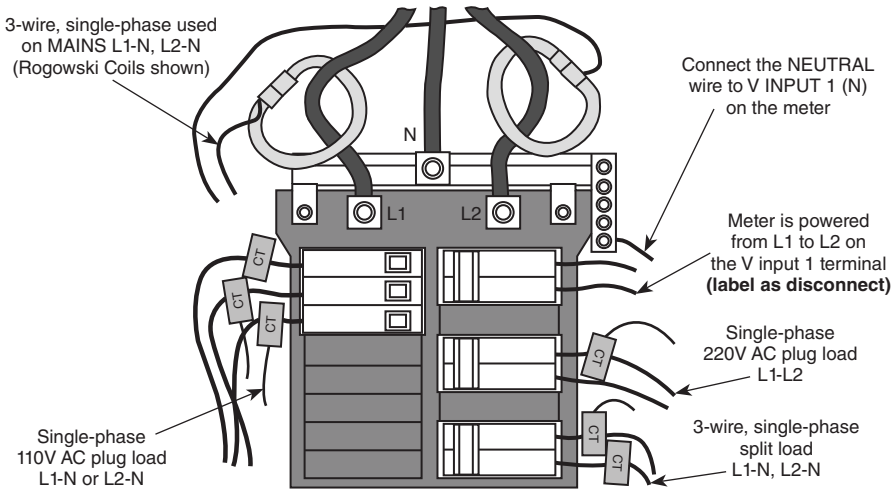

EXAMPLE LOADS:

- Single-phase L1-N or L2-N 110V AC: lighting, appliance, living zone
- Single-phase L1-L2 220V AC: water heater, clothes dryer, equipment with no neutral wire
- Split-phase L1-L2 220V AC: service entrance, equipment with neutral wire

b. Wiring in a 3-phase, 4-wire service panel.

Configurations shown are for service types available in the **METER SETUP** drop-down menu.

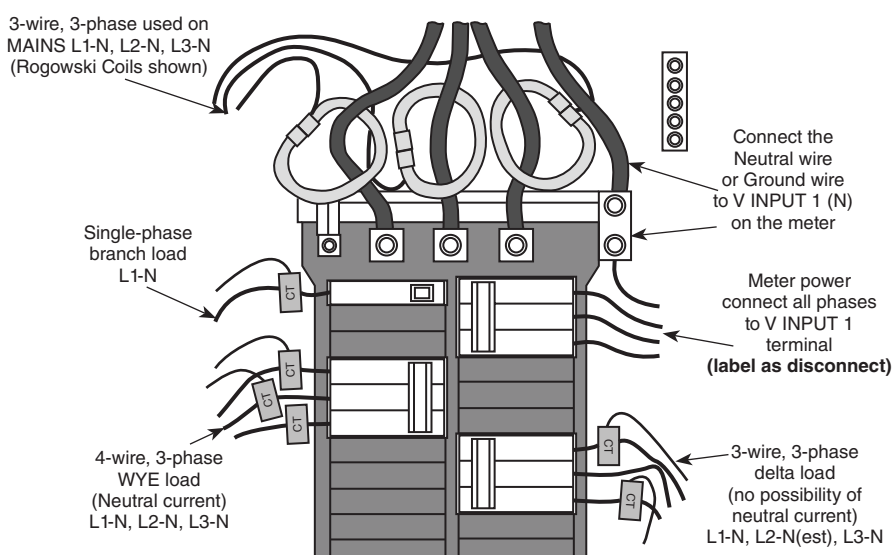

NOTE: The VerifEye meter series uses the NEUTRAL terminal as a voltage reference. For systems without a neutral conductor, Leviton suggests connecting a ground wire to this terminal. If the neutral terminal is left open, L-L measurements are accurate, but L-N measurements may not be symmetric. If a ground wire is connected to the NEUTRAL terminal, <2 mA flows into the ground wire.

2. Wiring the CTs to the meter.

The image to the right shows how to connect CTs to the input terminals on the S7000/7100 meters for each service type. For service types that are not listed, select **SINGLE PHASE** service from the drop-down menu, and configure each channel individually. The three-phase loads that are illustrated on the left and split-phase loads on the right, are examples only. Elements are interchangeable on the meter.

NOTE: Current and voltage inputs must be installed 'in phase' for accurate readings (e.g., CT1 on Line 1, CT2 on Line 2). Orientation is critical. Ensure that all CTs are properly oriented with the line and load, as marked. **Failure to install CTs in the correct orientation and on the correct phase leads to inaccurate meter readings.**

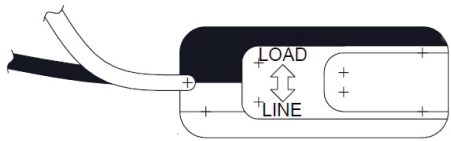

FCC STATEMENT:

This equipment has been tested and found to comply with the limits for a Class A digital device, pursuant to part 15 of the FCC Rules. These limits are designed to provide reasonable protection against harmful interference when the equipment is operated in a commercial environment. This equipment generates, uses, and can radiate radio frequency energy and, if not installed and used in accordance with the instruction manual, may cause harmful interference to radio communications. Operation of this equipment in a residential area is likely to cause harmful interference in which case the user will be required to correct the interference at his own expense. Any changes or modifications not expressly approved by Leviton Manufacturing Co., could void the user's authority to operate the equipment

IC STATEMENT:

This device complies with Industry Canada license-exempt RSS standard(s). Operation is subject to the following two conditions: (1) this device may not cause interference, and (2) this device must accept any interference, including interference that may cause undesired operation of the device.

FCC SUPPLIER'S DECLARATION OF CONFORMITY:

Models 71D12, 71D24, 71D48, 70D12, 70D24, 70D48, 71C12, 71C24, and 71C48 are sold by Leviton Manufacturing Inc. 201 N Service Rd, Melville, NY 11747. This device complies with part 15 of the FCC Rules. Operation is subject to the following two conditions: (1) This device may not cause harmful interference, and (2) this device must accept any interference received, including interference that may cause undesired operation.

TRADEMARK DISCLAIMER: Leviton and the Leviton logo are the registered trademarks of Leviton Manufacturing Co., Inc. VerifEye is a Leviton trademark registered in the U.S., Canada, and Mexico. Use herein of third party trademarks, service marks, trade names, brand names and/or product names are for informational purposes only, are/may be the trademarks of their respective owners; such use is not meant to imply affiliation, sponsorship, or endorsement. PhaseChek and TouchSaf are trademarks of Dent Instruments. Modbus is a trademark of Schneider Electric USA, Inc. and BACnet is a trademark of ASHRAE. Patents covering this product, if any, can be found on Leviton.com/patents

FOR CANADA ONLY:

For warranty information and/or product returns, residents of Canada should contact Leviton in writing at **Leviton Manufacturing of Canada ULC** to the attention of the **Quality Assurance Department, 165 Hymus Blvd, Pointe-Claire (Quebec), Canada H9R 1E9** or by telephone at **1-800-405-5320**.

LIMITED 5 YEAR WARRANTY

For Leviton's limited 5 year product warranty, go to www.leviton.com. For a printed copy of the warranty, call 1-800-824-3005.

© 2025 Leviton Mfg. Co., Inc.

For Technical Assistance Call: **1-800-824-3005 (USA Only)** or **1-800-405-5320 (Canada Only)** www.leviton.com

TECHNICAL SPECIFICATIONS

Service Types	Single phase, split-phase, three-phase four-wire (WYE), three-phase three-wire (Delta)
Voltage Input Channels	90-346V AC line-to-neutral, 600V L-L, CAT III For 48 Circuit Models Only: Two independent voltage reference inputs
Current Channels	12 to 48 channels, 0.525V AC max, 333 mV CTs, 0-4,000+Amps depending on current transducer
Maximum Current Input	150% of current transducer rating (mV CTs) to maintain accuracy. Measure up to 4,000A with Rogowski CTs.
Measurement Type	True RMS using high-speed digital signal processing (DSP) with continuous sampling
Line Frequency	50-60 Hz
Power	From L1 Phase to L2 Phase. 90-600V AC RMS CAT III 50/60 Hz, 500 mA AC Max Use of 12V auxiliary output requires 100V AC minimum input voltage.
AC Protection	0.5A Fuse 200 kA interrupt capacity
Power Out	Unregulated 12V DC output, 200 mA, self-resetting fuse
Waveform Sampling	1.8 kHz
Parameter Update Rate	1 second
Measurements	Volts, Amps, kW, kVAR, kVA, aPF, dPF, kW demand, kVA demand, Import (Received) kWh, Export (Delivered) kWh, Net kWh, Import (Received) kVAh, Export (Delivered) kVAh, Net kVAh, Import (Received) kVARh, Export (Delivered) kVARh, Net kVARh, THD, Theta, Frequency. All parameters for each phase and system total.
Accuracy	0.2% ANSI C12.20-2010 Class 0.2
Resolution	Values reported in IEEE-754 single precision floating point format (32 bit).
Indicators	4-line display, tri-color backlight (PhaseChek)
Pulse Inputs	Models 70D12, 71D12 - 4 inputs Models 70D24, 70D48, 71D24, 71C24, and 71D48 - 2 inputs
Alarm Output	Voltage Phase Loss Alarm (SPDT Relay - 30V DC) only

Communication

Hardware	RS-485, Ethernet, and USB (for configuration only)
Supported Protocols	Modbus RTU or BACnet Master Slave Token Passing protocol (MS/TP) Modbus (using SunSpec IEEE-754 single precision floating point model) Modbus TCP BACnet IP
Max Communication Length (RS485)	1,200 meters total length Belden 1,120A or equivalent cable, with Data Range of 100K bits/second or less
RS-485 Loading	1/8 unit
Communication Rate (baud)	Modbus: 9600 (Default), 19200, 38400, 57600, 76800, 115200 BACnet: 9600 (Default), 19200, 38400, 76800
Data Bits	8
Parity	None, Even, Odd
Stop Bit	2, 1
Termination	None provided

Mechanical

Wire Connections & Voltage	12-22 AWG 600V AC, Voltage connection must be #14 AWG or larger and rated 600V AC
Mounting	Enclosure or Panel Mount
High-Voltage Cover	IP30 (embedded version)
Operating Temperature	-4 to 140°F (-20 to + 60°C)
Humidity	5% to 95% non-condensing
Enclosure	ABS Plastic, 94-V0 flammability rating, connections sized for 1-inch EMT conduit
Dimensions	(L) 13.3 in. x (W) 9.8 in. x (H) 3.1 in. ((L) 33.7 cm x (W) 25.1 cm x (H) 8.0 cm) (enclosure version) (L) 10.3 in. x (W) 9.5 in. x (H) 3.1 in. ((L) 26.2 cm x (W) 24.1 cm x (H) 8.0 cm) (mounting plate version)
PCBA Dimensions	(L) 8.5 in. x (W) 8.5 in. x (H) 2.5 in. (21.6 cm x 21.6 cm x 6.4 cm)

VerifEye S7 Configuration Utilities Minimum System Requirements

Operating System	Windows® 7, Windows 8, Windows 10, Windows 11
Communications Port	USB or Ethernet connectivity
Certifications	FCC Part 15 Class A

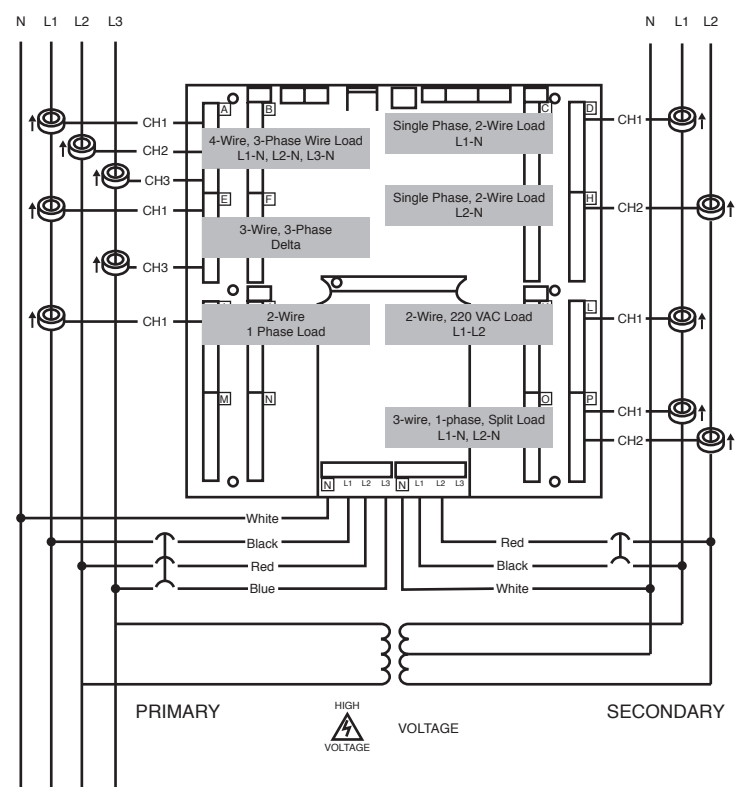

WEB VERSION